

O D 10 3/4" T. = 0.25"
 O D 12 3/4" T. = 0.25 Min.
 O D 14" T. = 0.25 Min.

Note:
 Pile shall be driven with a steel head having a projecting ring fitting inside the pipe. Clearance between ring and pipe should be 1/4".

Note:
 Pile pipe may be spiral welded, longitudinal welded, or seamless steel pipe.

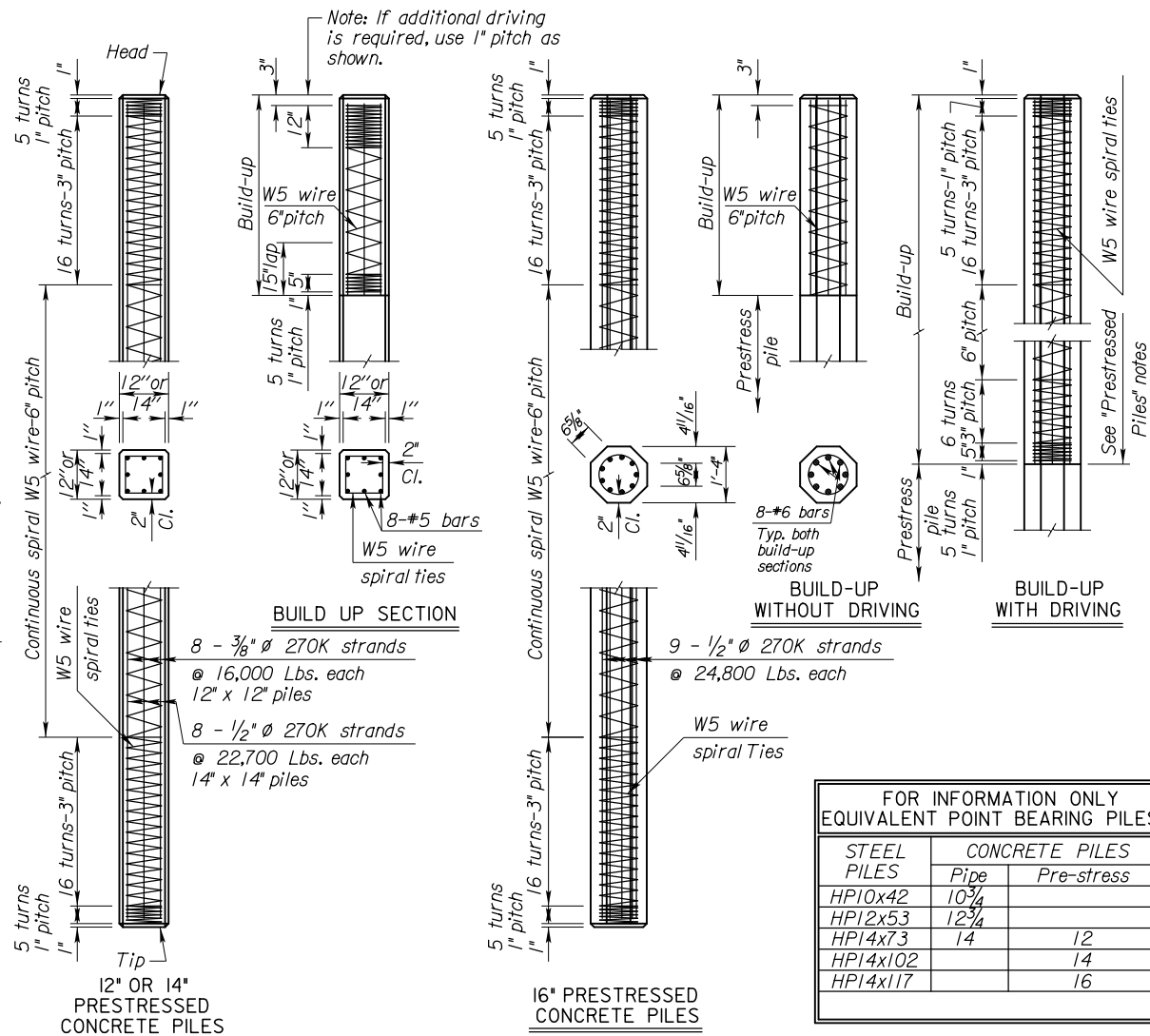
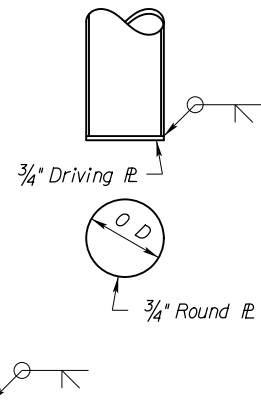

Note: If additional driving is required, use 1" pitch as shown.

PRESTRESSED PILES: Fabricate prestressed concrete pile splices in accordance with the Manufacturer's recommendations subject to the approval of the Engineer.

Method of attachment of pile to build-up may be by any of the methods given in the notes on "Alternate Methods. If mild reinforcing steel is used for attachment, the area shall be no less than that used in the build-up.

ALTERNATE METHODS: Method of attachment of a pile to build-up may be by any of the following methods:

1. Cut off at least 2'-0" of pile and expose a minimum of 2'-0" of strands.
 2. Cast 8-#6, or 8-#5 bars (equally spaced) into pile head. All bars shall extend into pile head and project from extend into pile head and project from the pile head a minimum of 2'-0".
 3. Drill 8 holes in pile head (equally spaced) for installation of 8 grouted dowel bars of same size and length as in 2.
 4. Provide cored holes for bars as in 3.
- No bars or strands are to extend from head of pile or build-up into footing or pile cap unless approved by the Engineer.

TEST PILES: Drive test piles where called for on the bridge plans. The test piles located within the limits of the substructure will become a part of the bridge pile system.

DRIVING FORMULA: Driving formula shall conform to the Standard Specifications.

MEASUREMENT AND PAYMENT: Measurement and payment for all piles shall comply with the Standard Specifications.

The following items are covered in Division 1000 of the Standard Specifications:

REINFORCEMENT: Use reinforcing steel conforming to ASTM A615, Grade 60. Hoops and spirals may be either plain or deformed bars.

PRESTRESSING STEEL: Use uncoated seven-wire stress relieved or low relaxation prestressing strand conforming to ASTM A416, Gr. 270.

FOR INFORMATION ONLY EQUIVALENT POINT BEARING PILES		
STEEL PILES	CONCRETE PILES	
	Pipe	Pre-stress
HPI0x42	10 3/4	
HPI2x53	12 3/4	
HPI4x73	14	12
HPI4x102		14
HPI4x117		16

GENERAL NOTES

STATE	PROJECT NO.	YEAR	SHEET NO.	TOTAL SHEETS
KANSAS	Proj. No.	YEAR	0	0

SPECIFICATIONS: Standard Specifications for State Road and Bridge Construction as currently used by the Kansas Department of Transportation. The following items are covered in Division 700 of the Standard Specifications:

CONCRETE: Concrete for cast-in-place shall be f'c = 3,500 PSI. Concrete for prestressed shall be f'c = 5,000 PSI.

WELDING: All field welding shall meet the requirements of the Standard Specifications.

Use only Shielded Metal Arch Welding (stick welding) for pile splices.

Use only low hydrogen E7018, 7016, or 7015 series welding rod (electrode) for all welding applications during pile splicing. See General Notes or proper storage of welding rod, welding filler rod (electrode) for field welding of splices.

New electrode are to be purchased for each KDOT project. The electrode shall arrive on the project in factory hermetically sealed containers opened and labeled with indelible ink in front of the engineer. The label shall include the current date and the project number. If the container seal is questionable or shows signs of damage the electrode is to be dried in an oven at least one hour at a temperature of 700°F to 800°F.

Upon removal from intact hermetically sealed factory packaging or the drying oven the electrode is to be placed in a storage oven with a minimum temperature of 250°F.

When electrodes are removed from the hermetically sealed container or storage oven and exposed to the atmosphere for less than 4 hours place into the storage oven for at least 4 hours before removing for use.

If electrode is exposed to the atmosphere for 4 hours or more (or 9 hours for moisture resistant electrodes designated with an R in their labeling) then electrode can be dried in a drying oven at a temperature of 450°F to 550°F.

If the electrode is exposed to the atmosphere for 4 hours or more a second time or the rod becomes wet discard rod.

CAST-IN-PLACE SHELLS: Steel shells for cast-in-place piles shall conform to the requirements of the Standard Specifications.

All piles driven without a mandrel shall be of the minimum thicknesses shown. Piles driven with a mandrel shall be of sufficient strength and thickness to withstand driving without injury and to resist harmful distortion and/or buckling due to soil pressure after the mandrel is removed.

Remove, replace or correct to the satisfaction of the Engineer improperly driven, broken or otherwise defective pipe piles. Otherwise drive an additional pile at no extra cost.

The Contractor shall maintain a light suitable for visual inspection of the pile on the job at all times prior to and during the filling of the pipe.

STEEL PILE: Steel pile shall conform to the requirements of the Standard Specifications.

PILE POINTS: Pile points shall conform to the dimensions shown and to requirements of the Standard Specifications.

PAINT: All paint shall comply with the Standard Specifications, or as specified on the plans.

MILL TEST REPORTS: Steel piles test reports and steel shell test reports shall comply with the Standard Specifications.

NO.	DATE	REVISIONS	BY	APP'D
4	06-18-12	Clarify fl. rod type, use and weld	JPJ	TLF
3	1-5-09	Pile Splice Location and Weld Test	JPJ	KFH
2	6-14-06	Rev. Pile Splice Note & Reinforcing	JPJ	KFH
1	11-12-03	Revised Notes	RAM	KFH

KANSAS DEPARTMENT OF TRANSPORTATION				
Br. No.				Sta.
Br. No.				Sta.
STANDARD PILE DETAILS				
BRIIO				Co.
FHWA APPROVAL	10-04-12	APP'D	Terry L. Fleck	
DESIGNED	JPJ	DETAILED		RAA
DESIGN CK.		DETAIL CK.		CADD CK.

PLAIN ROUND CAST-IN-PLACE CONCRETE PILES

CAST STEEL PILE POINT

The pile point shall be a one-piece unit of cast steel. Weld pile points in accordance with manufacturers recommendations to each steel pile before driving.

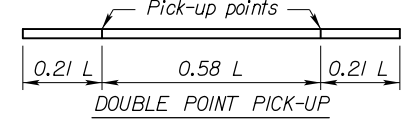
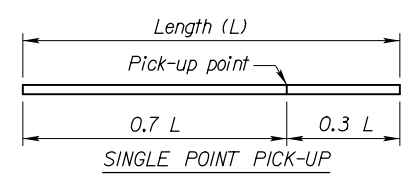

PICK-UP POINTS FOR PRESTRESSED PILING

Max. length - 55' single point pick-up
 Max. length - 80' double point pick-up

Note: Piles shall be marked at Pick-up points to indicate proper points for attaching handling lines.



Outside Flange

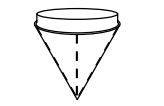

Inside Flange



H-Pile Point

PIPE PILE POINT

Weld Symbology Definition

Use grinder to bevel edges of splice as shown in weld symbology and drawing. In addition to bevels, produce clean, bare, and shiny surfaces at and around the splice welding location.

Use E7018, 7016, or 7015 series welding rod (electrode) for all welding applications during pile splicing. See General Notes for proper storage of welding rod.

Lay full penetration root weld from beveled side of splice.

Back gouge root weld from side opposite of root welding application making sure to remove all foreign materials, porous steel, and inclusions from root weld. Finish welding the non beveled side of the splice.

Finish welding beveled side of the splice while removing slag, foreign materials, porous steel, and inclusions in between welding passes, use of a grinder may be needed.

Verify that enough filler metal has been correctly placed in all weld locations to obtain a flush or convex surface with no concavity produced upon completion of the final welds.

SPLICES: Splices for steel piles and shell piling shall be in accordance with details shown on this sheet and the Standard Specifications.

For integral pile bent abutments and piers, if a pile splice is required, do not locate the pile splice within a region extending 2'-0" above and 10'-0" below the bottom of the concrete web wall. For abutments, locate the pile splice at least 10'-0" below the bottom of concrete.

With the approval of the Engineer, one splice per bent may be allowed in the region described above without testing. If additional splices are anticipated, based on the geology, the Contractor will add a sufficient amount to the bottom of pile, prior to driving, so that the splice is below the regions described above in the completed pile.

† For integral pile bent abutments and piers, if a splice is located within the regions described above, then the Contractor will test the welds by Radiograph (RT) test methods. Repair and retest any welds not passing the test(s). Each weld tested will have written confirmation of results. Report these results to the Engineer. This work is not paid for directly, but is subsidiary to "Piles".

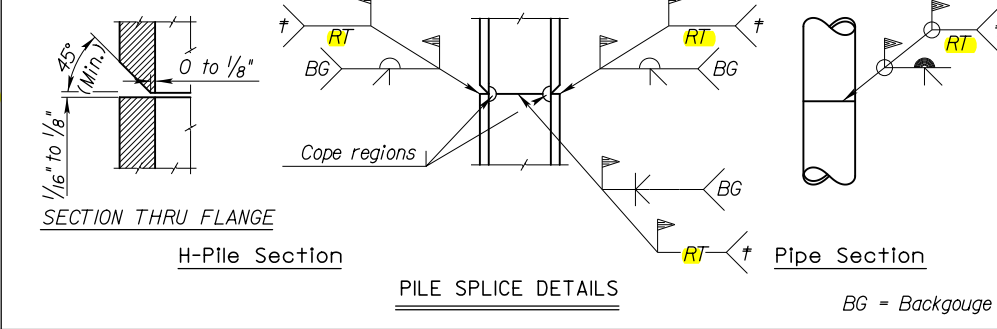

SECTION THRU FLANGE H-Pile Section PIPE SPLICE DETAILS Pipe Section BG = Backgouge

Std. Base File: br110.dgn
 Plotted By: rlang
 File: br110.dgn
 Plot Location: Bridge Design
 Plot Date: 08-OCT-2012 08:07