

# 6.0 Forms and Falsework

## *Table of Contents*

<b>6.0 TEMPORARY STRUCTURES</b> .....	<b>1</b>
6.0.1 General .....	1
6.0.1.1 Purpose .....	1
6.0.1.2 The Inspector's Role .....	2
6.0.1.3 Description .....	2
6.0.1.4 Specifications .....	4
6.0.2 Materials .....	4
6.0.2.1 Timber .....	4
6.0.2.2 Steel .....	6
6.0.2.3 Cable Bracing .....	7
6.0.3 Manufactured Systems .....	8
6.0.3.1 Overhang Brackets .....	8
6.0.3.2 Needle Beams .....	8
6.0.3.3 Ties, Wales and Strongbacks .....	9
6.0.3.3 Ties, Wales and Strongbacks .....	9
6.0.3.4 Gang Forms .....	11
6.0.3.5 Stay-in-Place forms .....	12
6.0.3.6 Plate Girder Forms .....	14
6.0.3.7 Friction Collars .....	14
6.0.3.8 Screw Jacks .....	15
6.0.3.9 Miscellaneous .....	15
6.0.4 Construction Requirements .....	15
6.0.4.1 Foundations .....	16
6.0.5 Formwork .....	18
6.0.5.1 General .....	18
6.0.5.2 Loads .....	18
6.0.5.3 Falsework Checklist .....	19
6.0.6 Basis of Payment .....	20

## *Figures*

Figure 1: Falsework and Formwork for Slab Bridges .....	3
Figure 2: Typical Falsework for Girder Bridges .....	3
Figure 3: Plywood Grain Orientation .....	4
Figure 4: Pre-coupled Z-shape Sheet Pile .....	6
Figure 5: Cable Bracing Detail .....	8
Figure 6: Overhang Bracket .....	8
Figure 7: Needle Beam System Components .....	9
Figure 8: Needle Beam Overhang Falsework .....	9

---

Figure 9: Vertical Formwork .....	10
Figure 10: Remaining Break Off Ties .....	10
Figure 11: Driven Posts and Strongbacks .....	11
Figure 12: Steel Forms .....	11
Figure 13: Steel SIP Forms and Welded Support Hangers .....	12
Figure 14: Steel SIP Form Installation .....	13
Figure 15: SIP "ladders" Welded In Place .....	13
Figure 16: Plate Girder Form System .....	14
Figure 17: Friction Collars Attached to Columns .....	15
Figure 18: Falsework Column Splice (Center) .....	16
Figure 19: Potentially Dangerous Column Splice Details .....	17
Figure 20: Incorrect Shim Placement .....	17
Figure 20: 3/4" Triangular Chamfer Strip .....	18
Figure 21: Placement and Initial Set of Concrete .....	19

## *Refernces*

References .....	20
------------------	----

**Disclaimer:** This website and documents are provided for use by persons outside of the Kansas Department of Transportation as information only. The Kansas Department of Transportation, the State of Kansas, nor its officers or employees, by making this website and documents available for use by persons outside of KDOT, does not undertake any duties or responsibilities of any such person or entity who chooses to use this website and documents. This website and documents should not be substituted for the exercise of a person's own professional judgment nor the determination by contractors of the appropriate manner and method of construction on projects under their control. It is the user's obligation to make sure that he/she uses the appropriate practices. Any person using this website and documents agrees that KDOT will not be liable for any commercial loss; inconvenience; loss of use, time, data, goodwill, revenues, profits, or savings; or any other special, incidental, indirect, or consequential damages in any way related to or arising from use of this website and documents.

---

## 6.0 TEMPORARY STRUCTURES

### 6.0.1 General

#### 6.0.1.1 Purpose

Bridges rely on a system of steel and cured concrete to carry traffic. To take a bridge from the plan sheets to a real world structure, parts of the system must be assembled before they can work together as a complete system. Temporarily securing individual elements of the structure is often required until the structure is in a permanent state. Temporary Structures introduce stability and safety into an incomplete structure to prevent damage to objects or equipment, collapse, injury, or loss of life of the construction crew or the traveling public.

Cast-in-place concrete requires a system to form it and support it while the concrete is liquid. This formwork provides the initial shape, and along with the falsework, provides the liquid concrete support until the concrete is set, cured, and strong enough to support itself.

Steel beams, or girders, may require a system to hold them in place until all the diaphragms, or crossframes, and splices are assembled. A steel superstructure may even require a bracing system until the deck concrete has been poured and gained enough strength to stiffen the structural steel system of girders or beams.

In phased construction and other special cases, embankment fill needs to be secured with some temporary structure such as sheet piling or soldier piling.

Cofferdams are temporary walls used to allow construction below the waterline in a river or reservoir. Cofferdam temporary structures require a vigorous design analysis, proper assembly and frequent inspection due to the repetitive, varying loading experienced by the structure.

As with any other structural system, temporary works are designed and built as economically as possible. However, a proper balance needs to be maintained between efficiency/economy concerns and impacts on the strength or stability of the permanent structure, and safety of field personnel and the traveling public.

In general, falsework does not fall down as often as it falls over. Using relatively straight members, sufficient bracing and adherence to the construction sequence spelled out in the Contractor's erection plan is the best way to reduce risk of falsework structure failure.

Experience, an eye for details, and common sense are the desired qualities of a falsework inspector. If something does not look right, or does not match what is shown on the erection plans, inspectors should discuss their concerns with the Contractor or other inspectors with experience in the area of concern. The State Bridge Office will review falsework plans and make comments on them, although it does not approve these plans for various reasons.

If, for any reason, the Contractor is unable to follow his proposed erection sequence, it is better to take the time to thoughtfully address obstacles instead of trying to rely on a makeshift plan and

hoping for the best. Trying to push forward through equipment problems, personnel shortages, bad weather, or other delays will likely set the Contractor further back than if the time is taken to properly assess the situation. The assessment may lead to taking action to address a few minor obstacles, or it may lead to starting the entire process over instead of pushing further into a bad situation or circumstance.

### **6.0.1.2 The Inspector's Role**

KDOT policy places design responsibility for formwork, falsework, shoring and other temporary works almost exclusively on the Contractor.

The Standard Specifications spell out some responsibilities the Contractor has as far as the quality of the falsework construction.

Depending on complexity, plans for temporary works may need to be stamped by a licensed Engineer.

The Contractor is responsible for constructing temporary works utilizing materials, including any substitutions of readily available materials for those specifically spelled out in the plans, which meet the minimum requirements the Engineer has specified. Temporary works shall be constructed to conform to the approved working drawings. The Contractor is responsible for the quality of the materials used in constructing the temporary structure. It is the Contractor's responsibility to verify the resulting temporary structure is consistent with the designer's original design.

Section 708 of the Standard Specifications requires certain falsework construction to be inspected, as-built, by the Engineer who stamped the plans prior to placing any concrete in the structure. This falsework is called Category 1 Falsework, and it is paid for according to the Standard Specification.

Category 2 Falsework does not require the Engineer who sealed the falsework plans to visit the site. However, design, inspection, and recommendation for approval by the Owner are still required. The Inspector should document any deviation from the temporary works plans, but responsibility for the appropriate design, construction and maintenance of temporary works until removal is upon the Contractor and the Contractor's engineer.

### **6.0.1.3 Description**

Formwork is the combination of elements used to shape the wet concrete until the concrete has set and reached the minimum cure. Formwork must be designed to resist two loads; the horizontal pressure of wet concrete against it, which increases when the concrete is vibrated, and the weight of the wet concrete between girders or beams. For girder bridges with typical girder spacing (under 14'), the structure between the girders used to support the wet concrete is considered formwork.

Falsework is the temporary structure used to hold parts of the permanent structure in place until those parts act as a complete system. Falsework supports the formwork. Falsework may also support parts of the substructure, superstructure girders or beams, and wet concrete. Overhangs on girder bridges as well as any temporary bracing for beams or girders are typically considered falsework. Falsework may also be called shoring, although this is more common in the building industry.

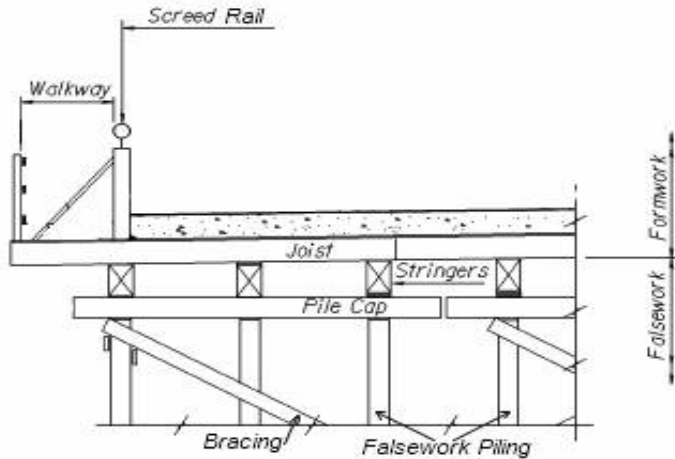

*Note: Min. vertical load to be used in the design of any falsework member shall be 100 psf measured over the total area supported by that member.*

**Figure 1: Falsework and Formwork for Slab Bridges**

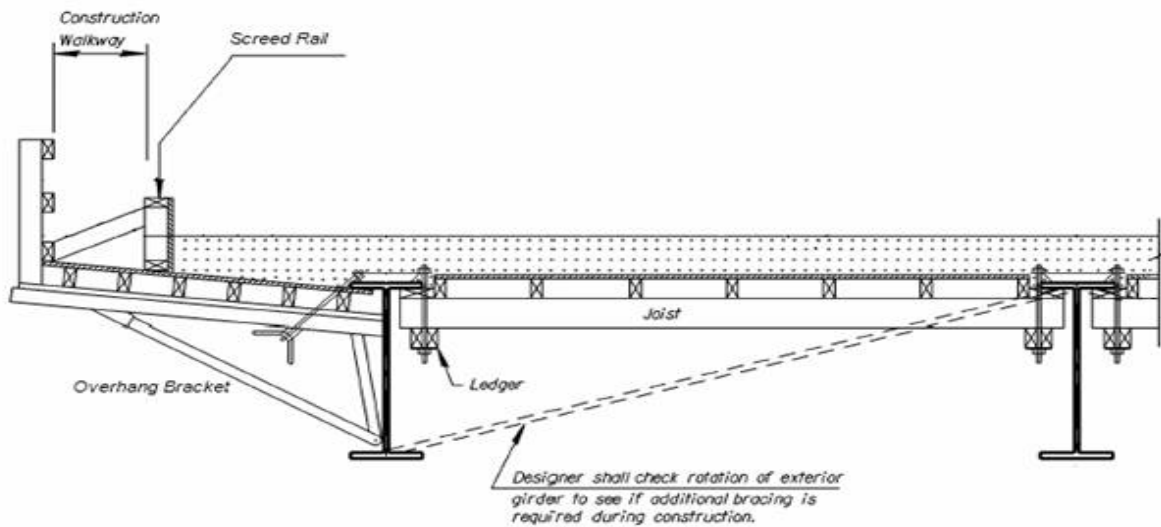

Typical Falsework for Girder Bridges

**Figure 2: Typical Falsework for Girder Bridges**

Cofferdams are constructed to hold back water to allow construction below the waterline in lakes and rivers. Cofferdams completely surround a component of the structure and must be watertight, as opposed to normal sheet piling systems that are typically not designed to be watertight. In similar fashion to a casing for a drilled shaft, a cofferdam provides a watertight air space to carry out construction of foundation or substructure elements. Loads acting on the cofferdam increase substantially with the depth of water. Water pressure increases 62.4 pounds per square foot for every foot of depth. At a relatively shallow depth of twenty feet, the cofferdam is resisting over twelve hundred pounds of pressure per square foot at the bottom of the lake or streambed. Site characteristics including impact from floating debris or aquatic vessels, tall waves, or high-velocity flows act to complicate the design of cofferdams.

### 6.0.1.4 Specifications

Requirements for temporary works are covered in the 2007 Standard Specifications in the following sections:

- 701 Temporary Shoring
- 702 Corrugated Metal Sheet Piling
- 708 Falsework & Form Construction
- 709 Steel Permanent Deck Forms
- 736 Field Erection
- 737 Controlled Demolition

## 6.0.2 Materials

### 6.0.2.1 Timber

Timber is the most commonly used multipurpose material for formwork and falsework. It can be used as bracing, struts, stiffeners, spreaders, walers, and forms. It is more labor-intensive to use an all-timber formwork system, since sections need to be made from scratch. Properly maintained timber formwork can be reused many times.

Plywood consists of thin strips of wood which are glued together in layers turned at 90 degrees to each other. The long direction is typically the strong direction.

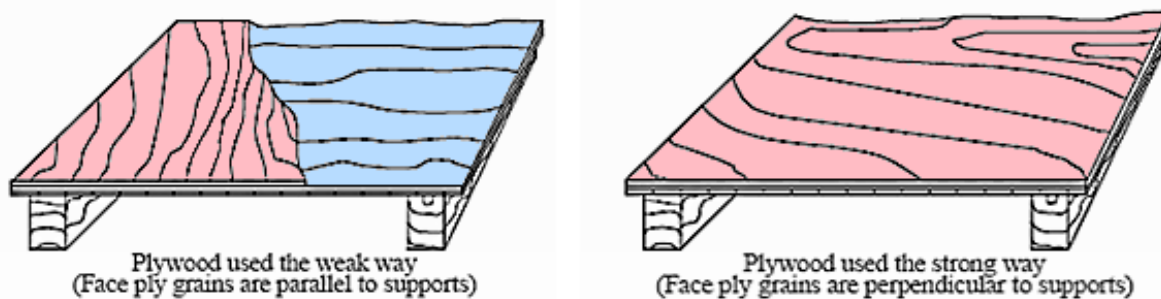

Figure 3: Plywood Grain Orientation

Sawn lumber, such as 2 x 4, 2 x 6, etc. are cut from logs and pressure treated to extend their life. Shims and blocking are usually cut from dressed (sawn) lumber.

Poles are pressure-treated, circular sections, commonly used for piling.

Because wood is an organic material, it is subject to variations in structure or properties or both. Some important characteristics of wood and the affect they have on the overall strength of wood members are as follows:

- Knots** – A knot is a portion of a branch or limb, which has been surrounded by subsequent growth of the wood of the trunk. Knots reduce the strength of wood because they interrupt the continuity and direction of wood fibers. Knots also cause local stress concentrations in the area surrounding the knot where the grain patterns have been abruptly altered. The amount of influence caused by a knot depends on its size, location, shape, soundness, and the type of stress considered. In general, knots have a greater affect on strength in tension than in compression, whether stresses are applied axially or as a result of bending.

- Slope of Grain** – Slope of grain or cross grain are terms used to describe the deviation in the wood fiber orientation from a line parallel to the edge of the specimen. It is expressed as a ratio such as 1 in 6 or 1 in 14, and is measured over sufficient distance along the piece to be representative of the general slope of the wood fibers. Slope of grain has a significant effect on mechanical properties. Strength, for example, decreases as the grain deviation increases. Specimens with severe cross grain are also more susceptible to warp and other dimensional deformations due to changes in moisture content.

- Checks and Splits** – Checks and splits are separations of the wood across or through the rings of annual growth, usually as a result of drying shrinkage during seasoning. Checks are partial depth separations, while splits extend through the full cross section. If members are subject only to tension or compression, checks or splits do not greatly affect strength. If checks or splits occur in zones of severe grain slope, they may affect strength characteristics to a greater degree.

- Member Size** – Timber members should be generally assumed to be standard dressed (S4S) sawn lumber unless otherwise shown on the falsework drawings. Section properties of S4S lumber are furnished in appendix A. While the sizes listed in Appendix 'A' are generally available on a commercial basis, it is good practice to consult the local lumber dealer(s) to confirm availability. Typically the dimensions of rough-cut lumber will vary appreciably from nominal, particularly in the larger sizes commonly used in falsework construction. If the use of rough-cut material is required by the falsework design, the actual member size should be verified prior to use.

**Used lumber should not be reused without careful inspection.**

As plywood is used and reused, the layers will begin to separate. This is called delamination. Delaminated sheets are not appropriate for formwork, but they can be used for temporary work platforms. Similarly, previously used forms with excessive concrete build-up, gouges or tool

marks should not be used as formwork. Using excessively worn forms, inferior grades or smaller thicknesses than required will cause an unsightly surface, excessive deflections or collapse.

### 6.0.2.2 Steel

Steel “beams” are considered to be rolled shapes rolled from solid pieces of steel into specified AISC sections with specified section properties. Beams are commonly I or C shaped and may be used as main beams, stringers or as piling.

Plate Girders are typically taller sections, welded together from plates. Girders are typically heavier, but allow the designer the flexibility to achieve greater spans with greater efficiency. It is rare to use a plate girder as anything other than a primary structural member.



**Figure 4: Pre-coupled Z-shape Sheet Pile**

Sheet piling is typically Z-shaped plate driven into the ground to contain soil. Each sheet will have a “ball” and a “knuckle” to lock onto the sheet next to it. Pile that has been visibly bent or damaged during a driving procedure, or pile with section loss due to rust, should not be used without prior approval.

Pile may be repaired by the manufacturer or processor for the removal of imperfections or depressions on the top and bottom surfaces by grinding. Repaired pile may be used, however, the area repaired may not have abrupt changes in contour and the grinding can not reduce the thickness of the plate:

- by more than 7 percent under the normal thickness for plates ordered to weight per square ft, but in no case more than  $\frac{1}{8}$  in or

- to less than the permissible minimum thickness for plates ordered to thickness in inches.

Imperfections on the top and bottom surfaces of plates may be removed by chipping, grinding, or arc-air gouging and then by depositing weld metal subject to the following limiting conditions:

- The chipped, ground, or gouged area shall not exceed 2 percent of the area of the surface being conditioned
- After removal of any imperfections in preparation for welding, the thickness of the plate at any location must not be reduced by more than 30 percent of the nominal thickness of the plate (ASTM A131 restricts the reduction in thickness to a 20 percent maximum.)

### 6.0.2.3 Cable Bracing

Bracing systems consisting of securely anchored cable guys are widely used to resist overturning of falsework. In particular, cable systems provide an effective means of providing stability to heavy-duty shoring and are relatively inexpensive when compared to other bracing methods. Cable is also used extensively as temporary bracing to stabilize falsework bents being erected or removed adjacent to traffic. However, the effect of preloading the tower legs should be carefully analyzed before implementing this bracing technique. The cable bracing should always be applied symmetrically to a shoring assembly to avoid unbalanced loading or overturning.

Cables, with their fastening devices and anchorages, are “manufactured assemblies” as defined in the FHWA publication, *Guide Design Specification for Bridge Temporary Works*. So, in addition to information that may be shown on the falsework drawings, the Contractor should be requested to furnish a manufacturer’s catalog or brochure showing technical data pertaining to the type of cable to be used. Technical data should include the cable diameter, the number of strands and the number of wires per strand, the ultimate breaking strength or recommended safe working strength, and other information which may be needed to identify the cable in the field.

Prior to installation, cable should be inspected to verify the type and size of the cable. The condition (new or used) of the cable should be consistent with design assumptions. Used cable should be inspected for strength-reducing flaws such as obviously worn, frayed, kinked, or corroded cable, which should not be permitted in construction.

U-bolt clips must be placed on the rope with the u-bolts bearing on the short or “dead” end of the rope, and the saddle bearing on the long or “live” end of the rope. An effective adage to remember which part of the cable fastener is installed where: “You never saddle a dead horse.” Improperly installed clips will reduce the safe working load by as much as 90 percent. Also, the omission of the thimble in a loop connection will reduce the safe working load by approximately 50 percent. After installation, clips should be inspected periodically and retightened as necessary to maintain their effectiveness. General guidelines regarding the number of wire rope clips and their spacing are shown in the figure below. However, efficiency factors and prescribed clip spacing’s can vary, and the cable manufacturer’s literature should be consulted for a given application.

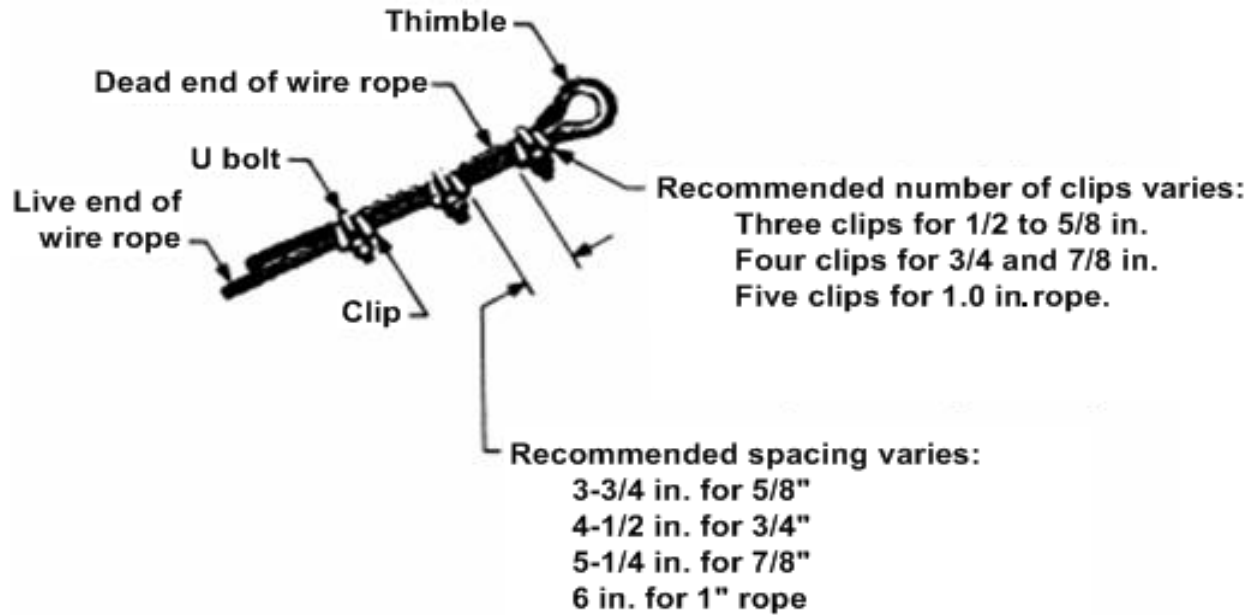

Figure 5: Cable Bracing Detail

## 6.0.3 Manufactured Systems

### 6.0.3.1 Overhang Brackets

Overhang brackets are typically used for forming deck overhangs. They bear against the web of the beam or girder, which can cause the beam to overturn or buckle if a system is not in place to counteract the overhang loads.



Figure 6: Overhang Bracket

### 6.0.3.2 Needle Beams

Overhang brackets aren't always the right tool for supporting overhangs. When shallow beams are used or the overhang is wide, the Contractor may elect to use needle beams. Small beams are attached to the bottom of the permanent superstructure beams as detailed in Figure 8. The deck formwork and overhang falsework is supported on columns that rest on the needle beams.

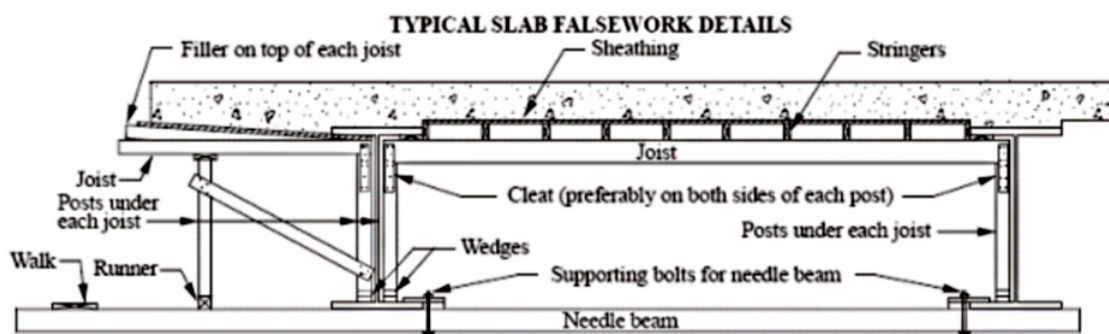

**Figure 7: Needle Beam System Components**

Since needle beams are considered to be “non-typical” falsework systems, the Contractor must have an engineer design and stamp plans for falsework using needle beams.



**Figure 8: Needle Beam Overhang Falsework**

### 6.0.3.3 Ties, Wales and Strongbacks

When wet concrete is poured into forms for vertical members, such as abutments and pier bents, the fluid pressure created by the concrete will try to push the forms apart. The Contractor will need to use multiple systems to keep the forms true to plan dimensions while the concrete hardens. Where possible, the Contractor will use sawn lumber to hold the forms to the proper dimensions.

One way to keep vertical forms from spreading in areas where lumber will not work is by using a snap-tie or a twist-off-tie system. The system consists of metal or plastic composite rods, wedges or cam-locks, and wales. The snap ties extend through the both sides of the forms and are secured by rods or cam-locks, and wedges are used to brace wales against the form wall. Whatever system the Contractor chooses, the system must be used as it was designed. For instance, the wedges shown below should be nailed to the wales so they cannot vibrate or work loose during concrete placement.



**Figure 9: Vertical Formwork**

After the forms have been removed, the ties must be removed to a point inside the face of the element. If the Contractor uses metallic ties, he must remove them to  $\frac{1}{2}$ " below surface of the element, and patch over the holes. This eliminates an open avenue for moisture to get deep into the concrete to possibly cause the reinforcing steel to rust.



**Figure 10: Remaining Break Off Ties**

To keep the forms vertical and plumb during the pour, the Contractor will use a system of strongbacks to tie the forms to the ground. The Contractor will drive a series of posts into the ground, and tie the forms to the posts using sawn lumber.



**Figure 11: Driven Posts and Strongbacks**

### 6.0.3.4 Gang Forms

On some structures, it is more efficient to use factory manufactured formwork instead of job-built formwork. Since manufactured forms are usually made out of steel, these systems are generally smaller yet heavier than the same system built out of wood. Since the forms come in large, fixed sizes, the structure may require extra forming to conform to plan dimensions.



**Figure 12: Steel Forms**

Aluminum gang forms are sometimes used in a similar fashion to manufactured steel forms. An aluminum system offers many of same advantages as steel forms, but the major advantage is the system is much lighter. One drawback of aluminum systems is a required form liner such as plywood. Aluminum will react with the cement and leave an unacceptable finish on the concrete, so the concrete and aluminum must be prevented from contacting each other by a form liner.

After gang forms are removed from the structure, any concrete that remains on the forms needs to be cleaned off before they can be reused to form another element of the structure.

### 6.0.3.5 Stay-in-Place forms

In areas where form removal is expensive or hazardous, the use of stay-in-place (SIP) forms may be desirable. SIP forms help facilitate the construction of bridge decks over high-traffic areas. The additional dead weight of the deck slab, appearance, and corrosiveness of the environment are some of the factors that should be considered when deciding if metal or precast concrete SIP forms should be used. Ribbed metal deck and precast concrete elements may act solely as formwork for cast-in-place concrete, or may act compositely with the concrete and become part of the load-bearing structure.

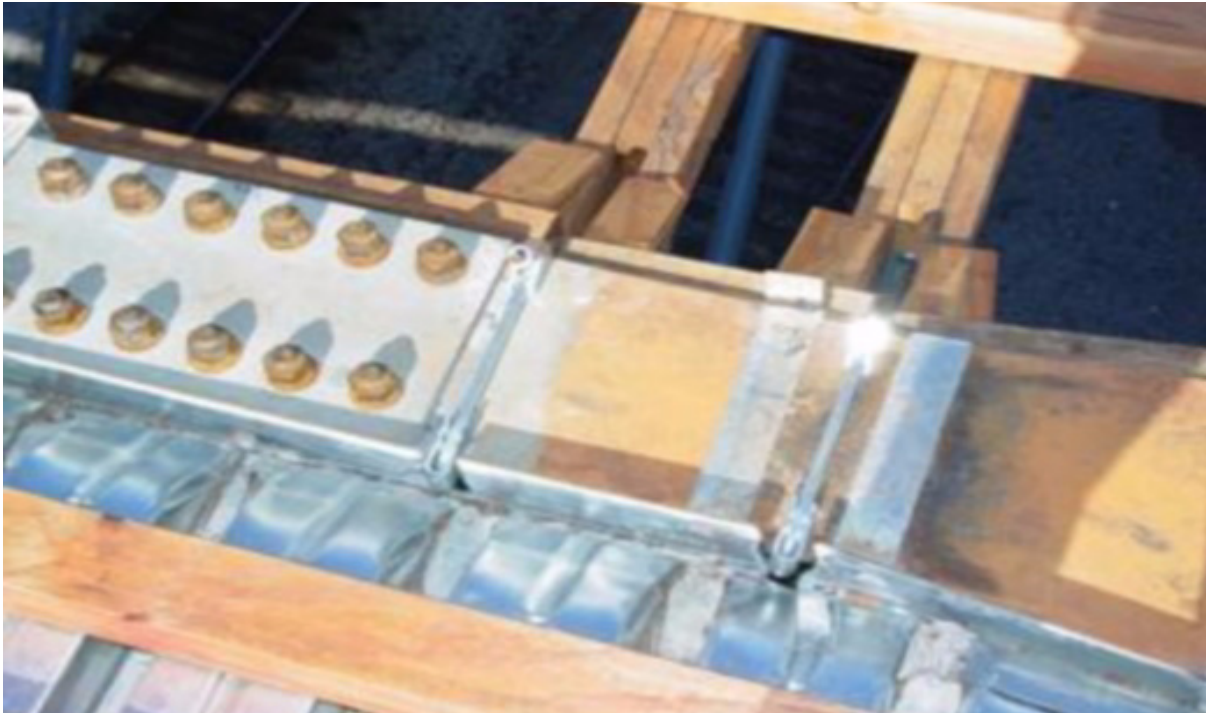

**Figure 13: Steel SIP Forms and Welded Support Hangers**

Corrugated metal or precast concrete panels may be used if shown in the contract documents or approved by the Engineer. Prior to the use of such forms, the Contractor shall provide a complete set of details to the Engineer for review and approval. Unless otherwise noted, the contract documents for structures should be dimensioned for the use of removable forms. Any changes necessary to accommodate SIP forms, if approved, shall be at the expense of the Contractor.



**Figure 14: Steel SIP Form Installation**

If the Contractor chooses to use steel SIP forms, many limitations must be taken into consideration during fabrication and installation. Welding to the top flange of the beams is prohibited, so the Contractor will need to set up a jig to fabricate the “ladders” that will receive the SIP forms. Fabricating the ladders in place on the girders can turn out to be a costly decision. Methods exist to fabricate and weld the ladders in place, but the Inspector(s) will need to remain very alert and attentive to prevent any damage to the beams.



**Figure 15: SIP "ladders" Welded In Place**

### 6.0.3.6 Plate Girder Forms

Plate girder forms, such as the one shown in figure 15, are well suited for the construction of bridge pier caps. These systems are capable of forming concrete while structurally spanning between supports with no intermediate shoring. In many applications these panels also will not require external walers. The large tie spacing and high pressure capacity provide form tie cost advantages in spite of the high form cost and weight. Larger plate girder modules create fewer joints to seal, align, and finish. The most significant cost-saving result is from the self-spanning capabilities of this system, which makes bridge pier construction possible while minimizing the amount of falsework.



**Figure 16: Plate Girder Form System**

In plate girder form systems, the web of the steel girder doubles as a form face. The steel ribs of the girder serve as web stiffeners to support the weight of the form and concrete. They also act as beams to transfer the horizontal pressures of the liquid concrete from the form web to the form top and bottom flanges. The plate girder forms come in modules that are bolted together, as needed, for specific projects. Proprietary bolting hardware allows the transfer of flange forces between individual modules, thereby allowing the formwork system to span between supports without intermediate shoring.

### 6.0.3.7 Friction Collars

On taller piers, pier beam falsework will usually not extend to the ground. It is more practical to use a system that interacts with the pier bent, such as a friction collar or bolts through the column. By clamping onto a pier column, the friction collar prevents the need to drill into the column or form a path for bolts. If the Contractor uses friction collars, he still needs to have posts bearing on

the ground in case the friction collars were to suddenly fail. The size of the columns and the method of supporting them should be determined by the Contractor's engineer.



**Figure 17: Friction Collars Attached to Columns**

### **6.0.3.8 Screw Jacks**

Screw jacks are required to adjust the elevation of the formwork to plan elevation. The capacity of the screw jack is reduced if the leg is fully extended.

Different proprietary falsework systems should not be mixed. For instance, EFCo forms should generally not be used with Gamco forms.

### **6.0.3.9 Miscellaneous**

Manufactured systems must have a form liner where they come in contact with fresh concrete.

Formwork must be mortar tight. If the cement and water paste is allowed to escape from corners and other joints in the formwork, it will leave a "honeycomb" finish of weakly pasted aggregate. This unsightly surface can be patched, but the patched area will have a shorter lifespan than a surface that is properly consolidated during concrete placement.

When aluminum formwork is used, the aluminum can not come in contact with concrete for prolonged periods. Aluminum reacts with chemicals in the cement and will damage the concrete. Aluminum finishing equipment is acceptable since it doesn't stay in contact with the fresh concrete for very long.

## **6.0.4 Construction Requirements**

When suitable materials have been selected, the Contractor has to construct the system. It is just as important to construct the falsework correctly as it is to choose good materials. Stability is a crucial issue in properly constructed falsework and formwork. Situations where falsework can tip

over, kick out, or separate must be considered in the design. Situations where this can happen must also be monitored in the field. Failure of either formwork or falsework will lead to delays in the project, a loss of quality in the structure, financial loss for the State and the Contractor, and possibly a loss of life of field people or the public.

#### 6.0.4.1 Foundations

Falsework shall be founded on a solid footing, safe against undermining, protected from softening, and capable of supporting the loads imposed on it. When requested by the Engineer, the Contractor shall demonstrate by suitable load tests that the soil bearing values assumed for the design of the falsework footings do not exceed the supporting capacity of the soil. Falsework which cannot be founded on a satisfactory footing shall be supported on piling which shall be spaced, driven, and removed in an approved manner.



**Figure 18: Falsework Column Splice (Center)**

The Contractor will attempt to avoid splicing falsework piling, but it cannot always be avoided. When the Contractor must splice falsework piling, the spliced members must be of similar diameter. There are many methods to splicing piling, but at a minimum, the splices should have one #6 dowel bar at least 2' long doweled into the center of the splice to prevent the splice from kicking out. The ends must be cut square. Shimming is not an acceptable method to straighten up a pile that was not driven plumb. Falsework piling should be driven to a tolerance of within ¼" per foot of length.



**Figure 19: Potentially Dangerous Column Splice Details**

Ends of timber piling should be cut square. Shims should not be required to make the piling plumb.



**Figure 20: Incorrect Shim Placement**

The shims shown in Figure 20 are not transferring any load from the deck to the falsework supports. This incorrect shim placement will allow the stringers to deflect excessively, which may open up seams between the sheeting. It would take very little effort to place new shims with a proper bearing area under the stringer beams.

## 6.0.5 Formwork

### 6.0.5.1 General

Concrete shall not be deposited in the forms until all work connected with constructing the forms has been completed, all debris has been removed, all materials to be embedded in the concrete have been placed for the unit to be cast, and the Engineer has inspected the forms and materials.

Forms shall be set and held true to the dimensions, lines, and grades of the structure prior to and during the placement of concrete. The Contractor is required to bevel all exposed edges by using dressed, triangular molding (“chamfer”) having  $\frac{3}{4}$  inch sides unless provided otherwise in the Contract Documents. The chamfer prevents uncontrolled cracking on these edges. On horizontal surfaces, the chamfer will be set at the elevation of the top of the concrete for the member.



**Figure 20:  $\frac{3}{4}$ " Triangular Chamfer Strip**

Forms may be given a bevel or draft at projections, such as copings, to allow easy removal.

Prior to reuse, forms shall be cleaned, inspected for damage, and, if necessary, repaired. When forms appear to be defective in any manner, either before or during the placement of concrete, the Engineer may order the work stopped until defects have been corrected.

Forms shall be treated with form oil or other approved release agent before the reinforcing steel is placed. Material which will adhere to or discolor the concrete shall not be used.

### 6.0.5.2 Loads

Falsework is any temporary structure designed to resist temporary loads determined in the preliminary or final design phase. The falsework designer needs to consider gravity loads from the

weight of the stationary structure, the moving live loads of workers, materials, and equipment, as well as wind and stream forces.

Special consideration must be given to the bottom portion of tall falsework (i.e. columns, webwalls, etc). Pressures from liquid concrete, or water in the case of cofferdams, increase a great deal with the depth of the liquid. Falsework designers should provide for and inspectors should verify the installation of adequate bracing to counteract these increased pressures. In the case of columns or webwalls, the rate of concrete placement could be limited to reduce the pressure load at the bottom of the formwork. As placed concrete begins the initial set it no longer exerts fluid pressure on the formwork, so as the depth of placed concrete increases at a similar pace to the initial set, the depth of fluid pressure exerted by the liquid concrete is maintained at a tolerable level.

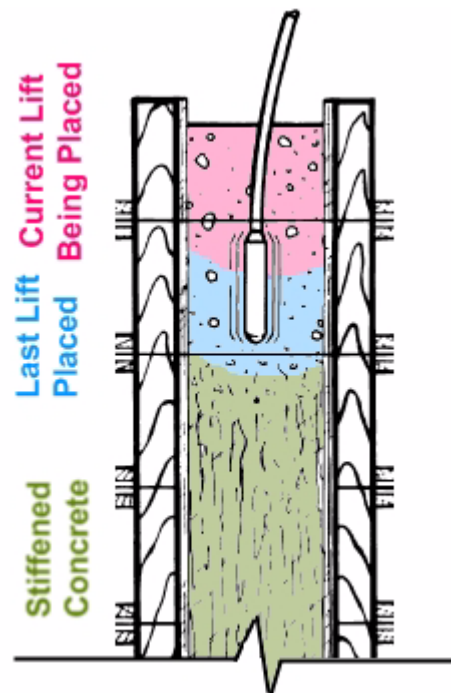

**Figure 21: Placement and Initial Set of Concrete**

Horizontal members span shorter distances, but support the whole weight of the concrete until it has set. These members still support part of the load until they have been removed.

Formwork should be checked regularly during the entire concrete pour for excessive movement, and a supply of extra bracing should be available.

Formwork should be erected as designed, and design assumptions such as placement rate and lift height should be discussed before a pour begins, and adhered to as closely as possible.

### 6.0.5.3 Falsework Checklist

As a minimum, the items on the following list should be checked on typical Category 2 Falsework. Falsework on needlebeams, proprietary falsework towers, and other non-typical systems require additional consideration as Category 1 Falsework.

- All of the drawings and written instructions have been strictly complied with.

- Only the correct materials in serviceable condition have been used, especially if specific types or qualities are required.
- The ground has been adequately prepared and steps taken to prevent erosion.
- Suitable foundation pads or other bases have been provided and have been properly leveled.
- Foundation pads, sleepers, and other load-distributing members laid on a slope are adequately prevented from movement down the slope.
- Any chocks or other supports are the correct shape and are adequately secured.
- Baseplates have been used and are properly spaced and centered on the supporting foundation pad.
- The extension of each screw or adjustable base is within the permitted limits and braced if necessary.
- Vertical members are plumb.
- Joints in vertical members are properly butted and aligned, and reinforced if required.
- The spacing and level of each lift of bracing members are correct.
- The number and position of all bracing members (longitudinal, lateral, and plan) are correct with connections close to node points.

### **6.0.6 Basis of Payment**

Temporary works are subsidiary to the bid items they're used on, such as Concrete Grade x.x, or Structural Steel.

Inspection of the Category 1 Falsework by the designer is paid according to the latest special provision.

### **References**

AASHTO LRFD Bridge Construction Specification

FHWA Construction Handbook for Bridge Temporary Works