

5.0 FALSEWORK DESIGN, ANALYSIS AND INSPECTION

- 5.1 REVIEW AND APPROVAL OF FALSEWORK PLANS 1**
- 5.2 DESIGN CONSIDERATIONS..... 4**
- 5.3 LOADS..... 5**
 - 5.3.1 Loads on Falsework 5
 - 5.3.1.1 Dead Load Densities 5
 - 5.3.1.2 Live Load 5
 - 5.3.1.3 Wind Load..... 6
 - 5.3.1.4 Lateral Load 6
 - 5.3.1.5 Vertical Load..... 6
 - 5.3.2 Loads on Formwork 6
- 5.4 ANALYSIS 9**
 - 5.4.1 Timber - Allowable Stresses 9
 - 5.4.1.1 Bending 9
 - 5.4.1.2 Horizontal Shear..... 10
 - 5.4.1.3 Compression Perpendicular to Grain 10
 - 5.4.1.4 Compression Parallel to Grain 10
 - 5.4.1.5 Fasteners..... 11
 - 5.4.2 Steel - Allowable Stresses 11
 - 5.4.2.1 Bending 11
 - 5.4.2.2 Column Compression..... 12
 - 5.4.2.3 Shear..... 12
 - 5.4.2.4 Web Crippling..... 12
 - 5.4.3 Deflection 13
 - 5.4.3.1 Formwork 13
 - 5.4.3.2 Falsework 13
 - 5.4.3.3 Uplift 13
 - 5.4.4 Soil Bearing..... 14
 - 5.4.5 Friction 14
- 5.5 MANUFACTURED ASSEMBLIES 17**
- 5.6 CONSTRUCTION PLAN NOTES RELATING TO FALSEWORK 17**
- 5.7 FALSEWORK REFERENCES..... 18**
- 5.8 EXAMPLE NO. 1 - FALSEWORK CHECK FOR STEEL GIRDER BRIDGE 21**
- 5.9 EXAMPLE NO. 2 - FALSEWORK CHECK FOR CONCRETE SLAB BRIDGE 44**
- 5.10 Structure Erection Calculations and Considerations..... 53**

List of Tables

- Table 5.1-1 FALSEWORK/FORMWORK..... 3

List of Figures

- Figure 5.3.2-1 Loads on Formwork and Loads on Falsework..... 7

Figure 5.3.2-2 Loads on Superstructure Supported Formwork	8
Figure 5.4.5-1 Formwork and Falsework Suggestions (1)	15
Figure 5.4.5-2 Formwork and Falsework Suggestions (2)	16
Figure 5-7-1-1i Deck Falsework on Girder Bridge.....	19
Figure 5.8-6(a) Finishing Machine Sketch	31
Figure 5.8.14(a) Example of TAEG 2.1 result summary.....	43
Figure 5.9-1 Example of Falsework Submission.....	45

5.0 FALSEWORK DESIGN, ANALYSIS AND INSPECTION

5.1 REVIEW AND APPROVAL OF FALSEWORK PLANS

The Contractor shall be responsible for designing and constructing safe and adequate falsework. The review or approval of falsework plans by the Engineer or permission to proceed with the work shall not relieve the Contractor of his responsibility for successful erection and satisfactory results. KDOT Specifications require that falsework plans and details be prepared and sealed by a registered Professional Engineer. It shall be the Contractor's responsibility to engage a registered Professional Engineer for design and plan preparation of falsework plans.

The KDOT Bridge Section (or design Consultant) will review falsework plans when requested by the KDOT Field Engineer. Falsework for bridges designed by a Consultant (at the locations noted below) shall be reviewed by that Consultant as part of the Construction Services phase of the Design Contract.

The review of falsework plans shall be documented in a letter from the bridge section (or design Consultant) directed to the Engineer and shall note recommendations, inadequacies or revisions that may be required. Approval or disapproval of the falsework plans and/or “as constructed” falsework shall be made by the Field Engineer.

The Contractor shall submit to the Engineer seven copies of detailed falsework plans for review and approval by the railroad company (where applicable) and the Engineer on the following structures:

1. All structures over or under railroad tracks
2. All structures built over highways or streets carrying traffic
3. All structures carrying highway traffic during construction
4. All structures requiring falsework plans as noted on contract plans

Three copies of detailed plans for falsework shall be submitted to the Field Engineer for review prior to falsework construction on those structures not listed in 1 through 4 above.

See [Table 5.1-1 FALSEWORK/FORMWORK](#) for guidance concerning the types of structural details that may require falsework/formwork plans to be submitted for Field Approval.

Seven copies of detailed plans for cofferdams and cribbing for footings on all structures adjacent to railroad tracks, shall be submitted to the Engineer for review and approval by the railroad company and the Engineer.

Work platforms or debris platforms used for concrete removal for widening or replacement of bridges over traffic ways or railroads shall be considered falsework, and falsework plans and

methods of support shall be submitted to the Engineer for review. It is not required that such plans for platforms bear the seal of a registered Professional Engineer, however, they shall meet all requirements of falsework for structural adequacy and safety.

Falsework drawings shall be reviewed and considered satisfactory by the bridge section (or design Consultant) before submission to other agencies. All falsework plans are to have the stamp shown below (or similar) with the appropriate date and box marked. If corrections are noted, mark the box titled, "RECOMMENDED FOR APPROVAL (AS NOTED IN RED)." Other considerations will be noted in the transmittal letter.

The Field Engineer will examine the falsework plan so that the drawings show the type, size, grade, and the finish of all lumber used. Also show the minimum size and type of falsework piling to be used, design piling loads, assumed live loads, concentrated equipment loads, screed loads and adequate details of the Contractor's proposed method of construction to permit checking by the Engineer. The drawings shall also bear the seal of a licensed professional engineer. To document that this review has been accomplished, the Field Engineer will date and initial the falsework plan. The Engineer shall be allowed a reasonable time to review any working drawings submitted by the Contractor for approval.

The Engineer may refuse permission to proceed with other phases of the work if he deems the falsework unsafe or inadequate to properly support the loads to which it will be subjected.

All falsework plans must have a stamp similar to the one shown below. Locate the stamp as close to the lower right hand corner of the sheet as possible.

DATE: _____

REVIEWER

- RECOMMENDED FOR APPROVAL _____
- RECOMMENDED FOR APPROVAL (AS NOTED IN RED) _____
- NOT RECOMMENDED FOR APPROVAL _____

Table 5.1-1 FALSEWORK/FORMWORK

For Structures listed in Spec. Prov. (1-4)	“Other” Structures not listed in (1-4)	Not required for review
1) Designed by P.E.	1) Designed by P.E.	1) Culvert spans \leq 16' or heights \leq 14'.
2) 7 sets* for review and comment by design.	2) 3 sets for Field review	2) Formwork
3) Field review of plans and approval of “as constructed” falsework/formwork.	3) Field review of plans and approval of “as constructed” falsework/formwork	3) Field approval of “as constructed” Falsework/formwork
	4) “Other” Structures may include:	
	a) Rigid Frame Boxes with spans > 16 ft. or heights > 14 ft.	
	b) Decks with girder spacing \geq 14 ft.	
	c) Deck overhangs with distance > beam depth or > 54 inches.	
	d) Substructure forming with “non-typical” support.	
	e) Superstructure forming with “non-typical” support.	

* Submit 3 sets for initial review.
7 sets required for final distribution.

5.2 DESIGN CONSIDERATIONS

Precise computations for falsework are not necessary. Many times the “worst case” scenario can be selected and checked. All falsework shall be designed and constructed to provide the necessary rigidity and to support the loads without deleterious settlement or deformation. Screw jacks or hard-wood wedges to take up settlement in the formwork either before or during the placing of concrete may be required.

See [2.2.2.4 Construction Clearances](#) for construction clearance requirements to public roads and railroads. Minimum clearance requirements are normally shown on the construction plans. Falsework supports adjacent to traffic ways must be protected by barriers and shall be designed to resist vibration forces caused by passing vehicles.

The importance of adequate diagonal and longitudinal bracing to the safety and stability of the entire shoring system cannot be overemphasized. Diagonal bracing must be provided in both vertical and horizontal planes to provide stiffness and prevent buckling of individual members of the falsework. Experience shows that most failures may be attributed to a lack of adequate lateral bracing (transverse or longitudinal) and a failure at one location may cause progressive failure for the entire structure (domino effect). Special consideration should be given to superelevated structures due to their inherent lateral instability and particularly to superelevated structures in combination with profile grades in excess of 4 percent.

Falsework bents shall be constructed with driven timber pile unless falsework can be founded in rock or shale. However, with approval, falsework pads may be used when underground utilities preclude the use of driven piling.

The Contractor is responsible for determining the safe bearing capacity of the foundation material on which the falsework supports will rest. Site drainage must be adequate to prevent soil saturation and washout of the soil supporting the falsework supports.

KDOT recommends the minimum bracing of timber bents to be 2 x 6 members with a minimum of two adequate fasteners (20d spikes or better) per connection. The bracing member must be able to resist both tension and compression. Steel bands should not be used for bracing or splicing load carrying members.

The Engineer shall confirm the type and size of lumber used in formwork and falsework. Most contractors will use S4S (standard dressed size). Rough cut (full size) may be used for pole caps and beams. Moments of inertia and weights must be adjusted for the type used.

5.3 LOADS

Formwork is considered to be the material or form that provides the shape to the concrete placement and the immediate structural system that supports the form.

Falsework is the structural system that supports the formwork.

Temporary bents or supports for beam or girder erection are also considered falsework.

5.3.1 Loads on Falsework

5.3.1.1 Dead Load Densities

Concrete:	160 lbs/ft. ³ (vertical, includes wt. of reinf. steel and forms)
(normal wt.)	85 lbs/ft. ³ (horizontal fluid pressure)
Timber:	50 lbs/ft. ³
Steel:	490 lbs/ft. ³
Formwork (light):	3-5 lbs/ft. ² (min.)
(heavy):	6-10 lbs/ft. ² (min.)

Timber and steel member densities from appropriate manuals may be used. A density of 10 lbs/ft.² may be estimated for timber formwork down to the falsework.

5.3.1.2 Live Load

The actual weight of equipment to be supported, applied as a concentrated load at point of application (screed rail, etc.) plus a uniform load of 20 lbs/ft.² applied over the entire area supported including the walkway. In addition, a load of 75 lbs/linear ft. shall be applied at the outside edge of the deck. (Note: This loading does not apply to superstructure supported formwork. See Section [5.3.2 Loads on Formwork](#)). To prevent an unrealistic loading condition when analyzing falsework members below the level of bridge soffit, it is KDOT's policy to limit the distance over which the 75 lbs/linear ft. loading will occur to a loaded zone 20 feet in length measured along the edge of the deck. The loaded zone will be viewed as moving load positioned to maximize stresses in the falsework member under consideration.

The Contractor furnished falsework plans should include expected concentrated equipment loads, including screed loads. If not, they should be requested by the reviewer.

5.3.1.3 Wind Load

20 psf exposed area (approx. 60 mph). Wind load should be considered for falsework over 30 ft. high.

5.3.1.4 Lateral Load

Minimum of 2 percent of total dead load. Superelevation and steep profile grades may combine to produce very large lateral loads. Falsework supporting bridge roadways with combination of profile grade and/or superelevation greater than 0.04 ft./ft. shall use a minimum lateral load of 4 percent of total dead load.

5.3.1.5 Vertical Load

The minimum vertical load to be used in the design of falsework member shall be 100 lbs/ft.² measured over the total area supported by that member.

5.3.2 Loads on Formwork

Loads on formwork shall be investigated for all members down to the main support members. For dead load, use the weight of the formwork plus the weight of the freshly placed concrete. For live load use 50 lbs/ft.² unless motorized carts are to be used in which case, 75 lbs/ft.² should be used over the deck area. The finishing machine shall be added as a concentrated load. The minimum design value of combined dead load plus live load on the bridge deck (excluding walkway) shall not be less than 100 lbs/ft.² (125 lbs/ft.² if motorized carts are used.) The walkway and supports should be designed for a live load of 50 lbs/ft.². (See [Figure 5.3.2-1 Loads on Formwork and Loads on Falsework](#)).

Superstructure supported formwork such as overhang brackets, deck walers, hangers and needle beams used on girder bridges are subject to direct and nonredundant load distribution and therefore it is KDOT's practice to design these members using the more conservative formwork loading as described above. (See [Figure 5.3.2-2 Loads on Superstructure Supported Formwork](#)).

With respect to falsework review requirements, the normal proprietary deck stringer/joist/overhang brackets used on girder bridges need only be reviewed if girder spacing or overhang distance exceed those shown in KDOT's specification. ().

However, due to deflection concerns and critical connection to the superstructure, needle beam supports should be reviewed as "falsework" and thus would require submittals to the Field Office.

Temporary structures, cofferdams, temporary sheeting and other non-conventional falsework or formwork will require submittal to the Field Office.

Figure 5.3.2-1 Loads on Formwork and Loads on Falsework

Note: Min. DL + LL on bridge deck (excluding walkway) = 100 psf (125 psf if motorized carts are used.)

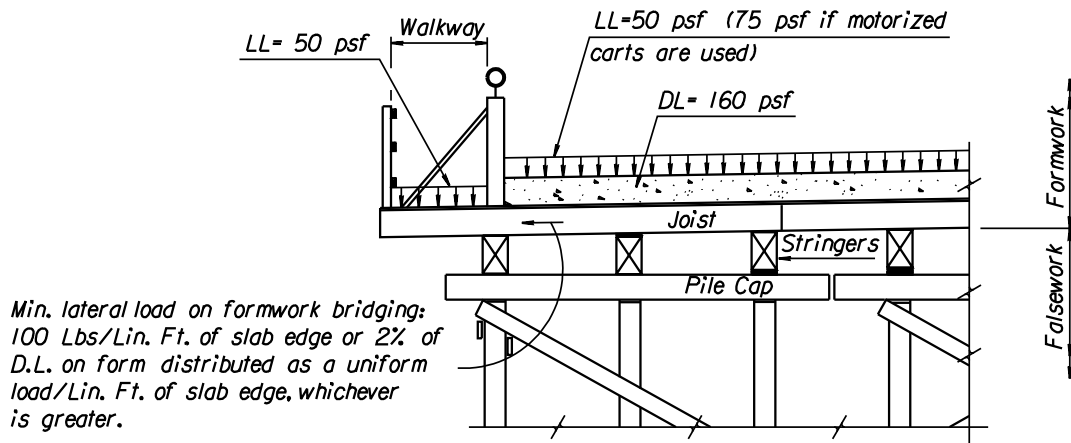

Loads on Formwork

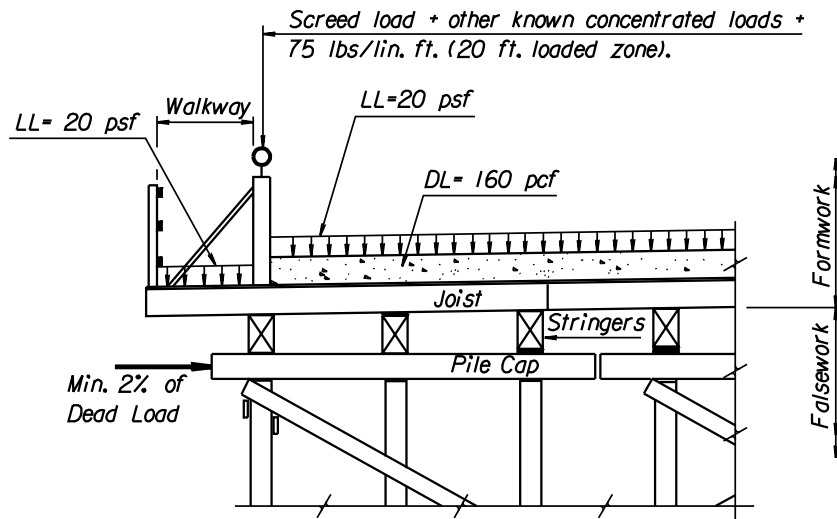

Note: Min. vertical load to be used in the design of any falsework member shall be 100 psf measured over the total area supported by that member.

Loads on Falsework

Figure 5.3.2-2 Loads on Superstructure Supported Formwork

Note: Min. DL + LL on bridge deck (excluding walkway) = 100 psf (125 psf if motorized carts are used).

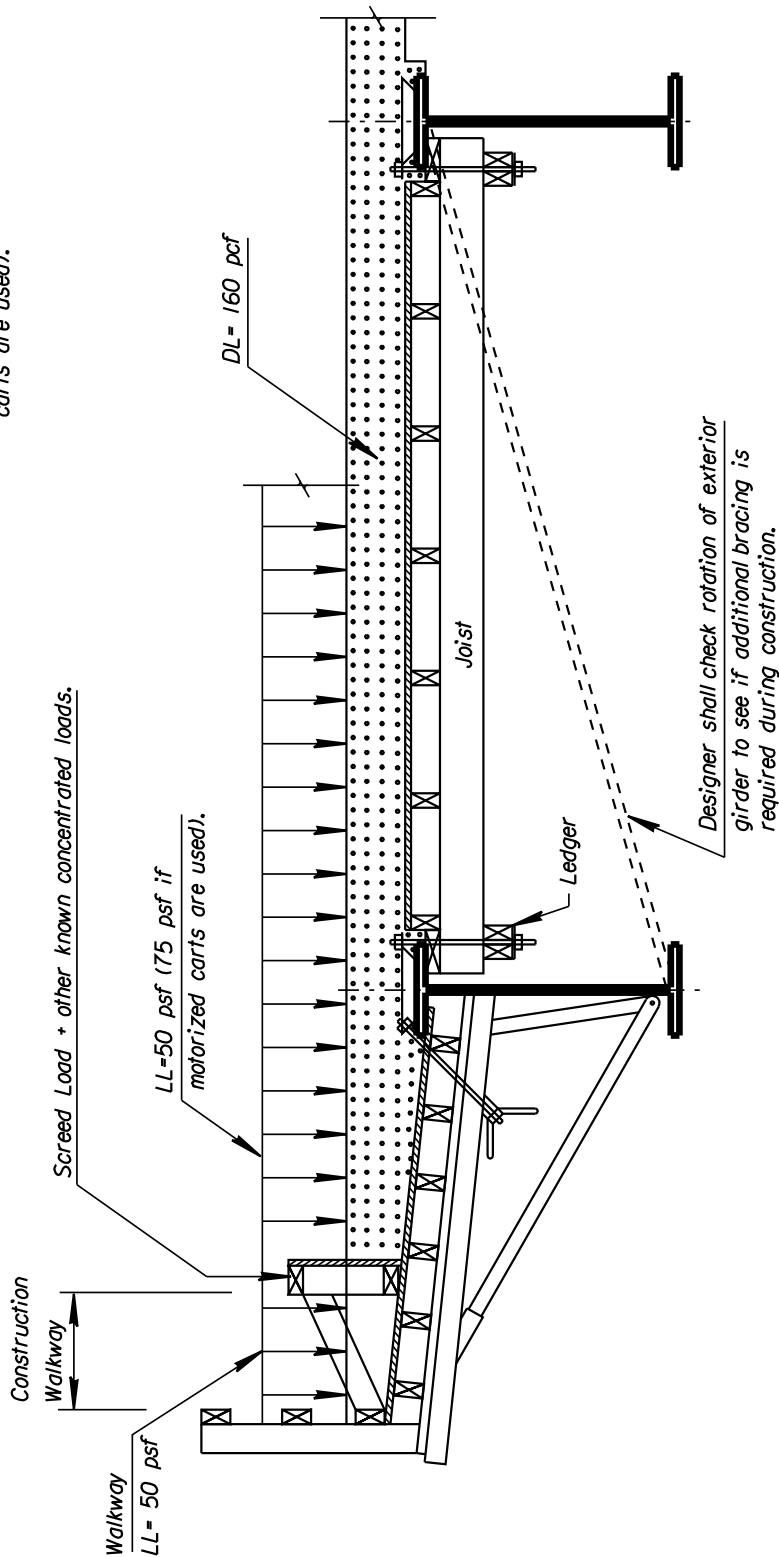

Loads on Superstructure
Supported Formwork

5.4 ANALYSIS

In general, due to the condition of used material, the variance in quality of construction, unexpected construction loads and the consideration of safety for construction personnel and the traveling public, it will be KDOT's policy to use conservative values of allowable structural capacity.

Unless otherwise directed on the plans, used material will be permitted when it conforms to the dimensions and material specified on the falsework plans. Used material shall be free of splits, cracks, holes, etc. that will reduce the structural capacity. No. 2 Grade or better material is required.

When the Contractor can certify his material is capable of supporting a greater stress, higher values may be used.

5.4.1 Timber - Allowable Stresses

5.4.1.1 Bending

$$f = Mc/I \leq 1,200 \text{ psi}$$

Beams shall be checked for stability. Inadequate bracing may allow the compression edge of the beam to buckle under a load which it would otherwise be capable of carrying. The amount of restraint needed for stability is a function of the depth-to-width ratio. The following guidelines may be used to determine the need for bridging or blocking of joists and wood beams:

If the nominal depth-to-width ratio of a timber beam is 2:1 or less, no lateral support is needed.

If the nominal depth-to-width ratio is 3:1, the ends of the beam should be held in position.

If the ratio is 4:1, the ends shall be held in position and the member held in line as by purlins or sag rods.

If the ratio is 5:1, the ends shall be held in position and the compression edge held in line as by direct connection of sheathing, decking, or joists.

If the ratio is 6:1, the ends shall be held in position and the compression edge held in line as for 5 to 1, together with adequate bridging or blocking spaced at intervals not exceeding 6 times the depth.

If the ratio is 7:1, the ends shall be held in position and both edges firmly held in line.

5.4.1.2 Horizontal Shear

$$H = 3V/2bd \leq 120 \text{ psi (for rectangular beam)}$$

Shearing stress may determine the size of member required where short spans are heavily loaded. When computing “V”, neglect all loads within a distance from the face of support equal to the depth of the beam.

If the allowable stress is exceeded when computed by the above general formula, the shear value “V” may be determined by using the checked-beam formula. See references for discussion of the checked-beam method.

5.4.1.3 Compression Perpendicular to Grain

$$F_c = P/A \leq 400 \text{ psi}$$

For bearings less than 6" long and not nearer than 3" to the end of a member, the maximum allowable load per square inch is obtained by multiplying the allowable unit stress in compression perpendicular to the grain by the factor:

$$\frac{L + 3/8}{L}$$

where L = length of bearing in inches.

5.4.1.4 Compression Parallel to Grain

$$F_c = 850 \text{ psi}$$

Falsework posts may be considered as pinned at top and bottom, regardless of the actual end condition. The maximum allowable stress depends on the slenderness ratio. Timber posts are classified as short, intermediate or long depending on the failure mode. **The design load for a column of round cross-section shall not exceed that for a square column of the same cross-sectional area.**

For short posts ($L/d \leq 11$): $F_c' = F_c \leq 850 \text{ psi}$

where

- F_c' = adjusted allowable compression parallel to grain
- L = unsupported length
- d = least dimension

For intermediate posts ($11 < L/d < K$):

$$F_c' = F_c \left[1 - \frac{1}{3} \left(\frac{L/d}{K} \right)^4 \right]$$

where

$$K = 0.671 \sqrt{E/F_c}$$

$$E = \text{modulus of elasticity of wood}$$

$$= 1,500,00 \text{ psi}$$

For long posts ($K \leq L/d < 50$):

$$F_c' = \frac{0.30 E}{(L/d)^2}$$

Driven timber piling shall be subject to the above criteria; however, the maximum design loads for driven piling shall not exceed:

$$\begin{array}{ll} 8" \text{ diameter} & = 10 \text{ ton/pile} \\ 10" \text{ diameter} & = 16 \text{ ton/pile} \end{array}$$

Compute pile capacity using the ENR pile driving formula.

5.4.1.5 Fasteners

For lateral load and strength of fasteners consult the ACI 347 Formwork book. It is KDOT policy to assume, for temporary structures, 100 percent of allowable design values may be used for lag bolts, nails, spikes or thru bolts. When wind load is a design factor, connection values may be 125 percent of design values.

5.4.2 Steel - Allowable Stresses

5.4.2.1 Bending

$$f = Mc/I \leq 18,000 \text{ psi} \quad (f_y = 33,000 \text{ psi})$$

If the compression flange is supported, this formula is sufficient to determine the section needed to carry the applied load for a beam in bending. If the compression flange of a beam is not supported, the maximum allowable bending stress must be reduced to prevent flange buckling. The strength of beams in lateral buckling is quite complex due to the many factors involved. However, the following formula may be used to estimate the allowable stress:

$$f(\text{maximum}) = \frac{12,000,000}{Ld/bt} \leq 18,000 \text{ psi}$$

where L = unsupported length (inches)
 d = beam depth
 b = flange width
 t = flange thickness

In determining the lateral support of compression flanges developed by other falsework members, it is KDOT policy to neglect friction between the joists and top flange of a beam.

When bracing steel beams, it is important to realize that timber cross-bracing alone will not prevent flange buckling because timber struts alone resist only compression forces. The most effective bracing system would use the wood cross-bracing in combination with steel tension ties secured across the top and bottom of adjacent beams.

5.4.2.2 Column Compression

$$P/A = 16,000 - 0.38(L/r)^2$$

where r = radius of gyration
 L = unsupported length
 (limiting L/r value is 120)

When the L/r limiting value is exceeded, additional bracing can be added to decrease “L” or use a larger section to increase “r”.

The above formula assumes an effective length factor of 1. Determining the actual effective length of a column with fixed or restraint ends is unnecessary. Treating columns ends in falsework bents as being pinned is conservative for columns with end restraints.

5.4.2.3 Shear

$$v = V/ht < 11,000 \text{ psi}$$

where h = depth of beam
 t = web thickness

5.4.2.4 Web Crippling

Beams should be checked at interior and end reactions to make sure the compressive stress in the web of the toe of the fillet does not exceed 25,000 psi. The following are governing formulas:

For interior reactions,

$$f = R/t(N+2k)$$

For end-reactions,

$$f = R/t(N+k)$$

where R = concentrated load or reaction, lbs.
t = thickness of web, inches
N = length of bearing, inches
k = distance from outer flange to web toe of fillet, inches

When the actual value exceeds the allowable, the web should be stiffened or the bearing area increased.

5.4.3 Deflection

NOTE: When checking deflections, use dead load only.

5.4.3.1 Formwork

The deflection for formwork should be limited to span/360 with a maximum of 1/16" for deck plywood and 1/4" for walers.

5.4.3.2 Falsework

For falsework the deflection shall be limited to span/240 with a maximum of 1". Whenever the deflection on falsework beams exceeds 1/4", adjustments should be made at the quarter points.

5.4.3.3 Uplift

Negative deflection may occur where falsework beams are continuous over a long span and a relatively short adjacent span. Beam lift-off can be prevented by loading the short span first, or by restraining the end of the beam.

Cantilevered falsework spans will also produce an upward deflection which must be considered. Movement may be controlled by blocking of the main span.

5.4.4 Soil Bearing

When checking the adequacy of a spread footing or sill, use the following allowable bearing values:

Below average soil	-	2,000 psf
Average soil	-	3,000 psf
Pavement	-	6,000 psf

Soil can be classified as average if it is firm enough to walk on without indentation of the heel of a shoe. Jacks may be required for adjustment of falsework due to settlement. Longitudinal bracing between bents founded on sills may be required to provide stability from lateral forces.

5.4.5 Friction

Coefficient of Friction:	steel on steel	0.10
	steel on wood	0.20
	wood on wood	0.30

Do not rely on friction for lateral support. Vibration, uplift, partial loading, etc., can reasonably be expected to reduce contact bearing during placement or erection.

Figure 5.4.5-2 Formwork and Falsework Suggestions (2)

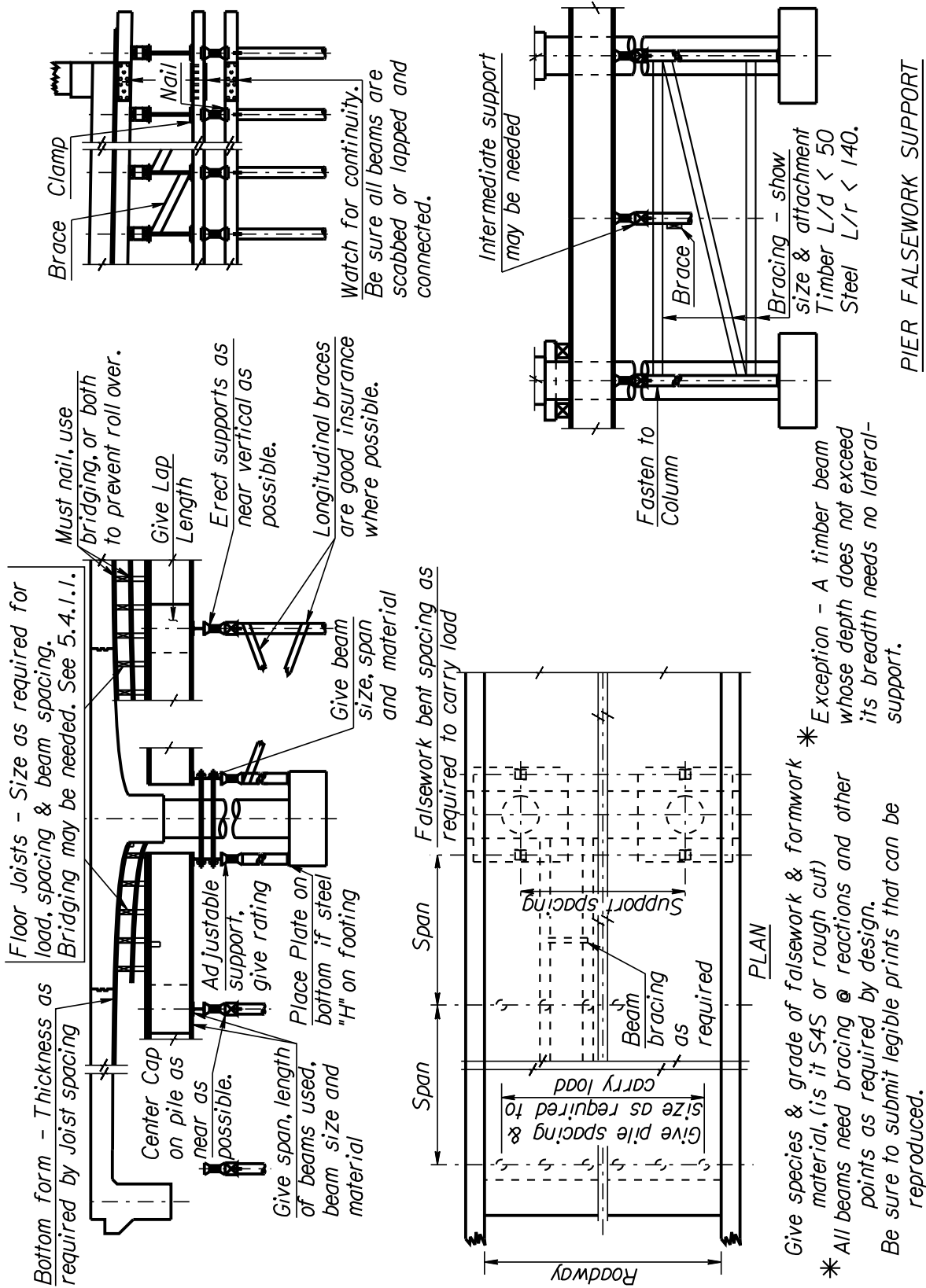

5.5 MANUFACTURED ASSEMBLIES

If stock form accessories are used, the Contractor should submit technical data or a “Statement of Compliance” from the Contractor and signed by the manufacturer pertaining to the product showing safe load, material, intended use, how spliced or lapped and how attached. Examples are:

- Jacks
- Coil ties
- Coil rods
- Overhang brackets
- Metal scaffolding

The Engineer must be able to verify that the item is being used as the manufacturer intended.

When using overhang brackets on steel girders, the lateral loads applied to the girder flanges will produce an overturning moment in the girder. It also places a lateral force into a compression flange that already wants to kick out. A composite beam is rather weak without the deck and could be severely loaded under construction loads. Additional temporary struts and tension ties may be required to prevent overstressing of the permanent diaphragm connections.

5.6 CONSTRUCTION PLAN NOTES RELATING TO FALSE-WORK

The following plan notes should be used concerning falsework and camber for concrete slab bridges:

NOT4100, 4110, 4120, 4130, 4140, 7800 and 7810

The following plan note should be used concerning falsework bents at field splices and would be applicable to either bolted or welded connections for steel girders:

NOT6520

Standard Notes can be found on the Internet at http://www.ksdot.org/burdesign/standard_notes/usstdnot.doc

5.7 FALSEWORK REFERENCES

1. KDOT Construction Specifications, 1990, 7013(b), p. 376 and 702.07(d), p. 403.
2. Standard Specifications for Highway Bridges, AASHTO, 17th Edition, 2002, Div. II Construction, Section 3, Temporary Works
3. "Formwork for Concrete," American Concrete Institute, Publication SP-4, 4th Edition, 1979 and 5th Edition, 1989.
4. "Timber Construction Manual," American Institute of Timber Construction, 3rd Edition, 1985
5. "Wood Structural Design Data," National Forest Products Association, 1970 Edition
6. "Timber Design and Construction Handbook," Timber Engineering Company, 1956
7. "Douglas Fir Use Book" Structural Data and Design Tables, Western Wood Products Association (formerly West Coast Lumbermen's Association), 1961 Edition
8. "Formwork for Concrete Structures," R.L. Peurifoy, 1964
9. Bridge Deck Forming Handbook, 1983 Dayton Superior Corporation
10. Falsework Manual, State of California, Jan. 1988
11. Bridge Design Manual-Bureau of Design
12. Manual of Steel Construction, AISC, 9th Edition
13. Charles G. Salmon and John E. Johnson, "Steel Structures: Design and Behavior," Second Edition, Harper and Row, New York, 1980.
14. "Design for Concrete Deck Overhang Loads" AISC Marketing, Inc., June 15, 1990 (Final Report)
15. "Torsional Analysis of Steel Members" AISC, 1983

Figure 5-7-1-1i Deck Falsework on Girder Bridge

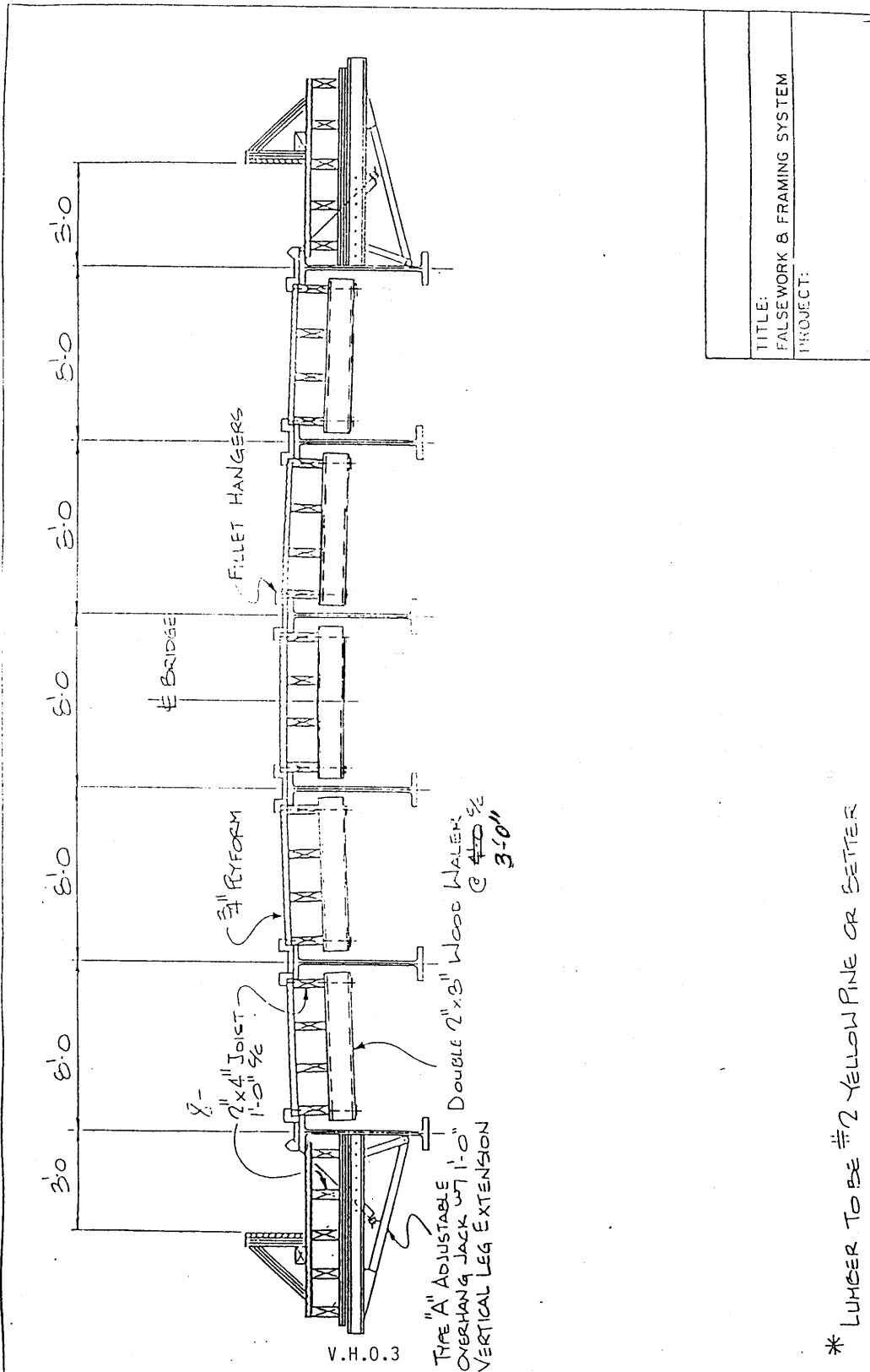

BRIDGE OVERHANG SUPPORT BRACKET

Working Load: 3,600 Lbs. Maximum
(Based on 1/2" Dia. Tie Hardware)

Adapts to Precast Beams, Types I-IV.

Can Be Modified to Fit Types V & VI.

Features adjustment in legs which is ideal for super elevations.

Fine adjustment suggested after loading.
Adapts to steel beams:

Vertical Leg	Std. Leg	Short Leg	X-Short Leg
Max. Height	2'6 ³ / ₄ "	1'9 ³ / ₄ "	1'3"
Min. Height	1'10 ³ / ₄ "	1'3 ³ / ₄ "	1'1"

Weight: 50 Lbs.

Patent Pending

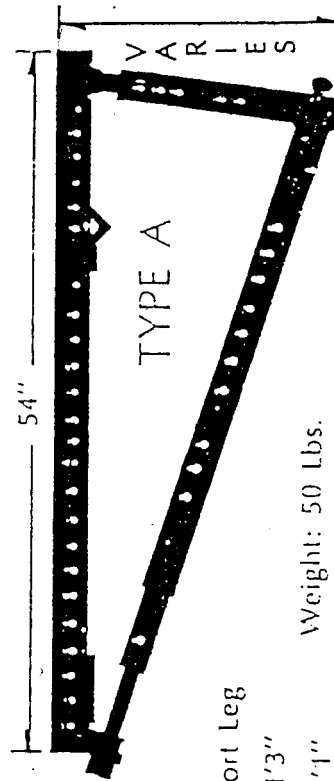

5.8 EXAMPLE NO. 1 - FALSEWORK CHECK FOR STEEL GIRDER BRIDGE

Ref: "Formwork for Concrete", 4th Edition, 1979, American Concrete Institute, Publication SP-4.

Check falsework and framing system submitted for a 116'-145'@100'-65' Continuous Steel Plate Girder (Composite). The cross-section has 6 girders under a 44'-0" Roadway.

(When reviewing falsework plans, the checker must be aware that the picture does not always show what the contractor needs to build. The falsework system submitted by the contractor for this bridge shows only 4 joists, when in fact, 8 joists are required (See Sheet [Figure 5-7-1-1i Deck Falsework on Girder Bridge](#)). This type of inaccuracy should be noted and corrected to avoid possible confusion in the field.)

A catalog clip of the proposed overhang bracket is attached. This information should come with the review request. If information on hardware is not received, request it.

Check center bay. Falsework plans were submitted for Double 2 x 8 walers at 4'-0" centers. Some form of beam hanger will support the walers.

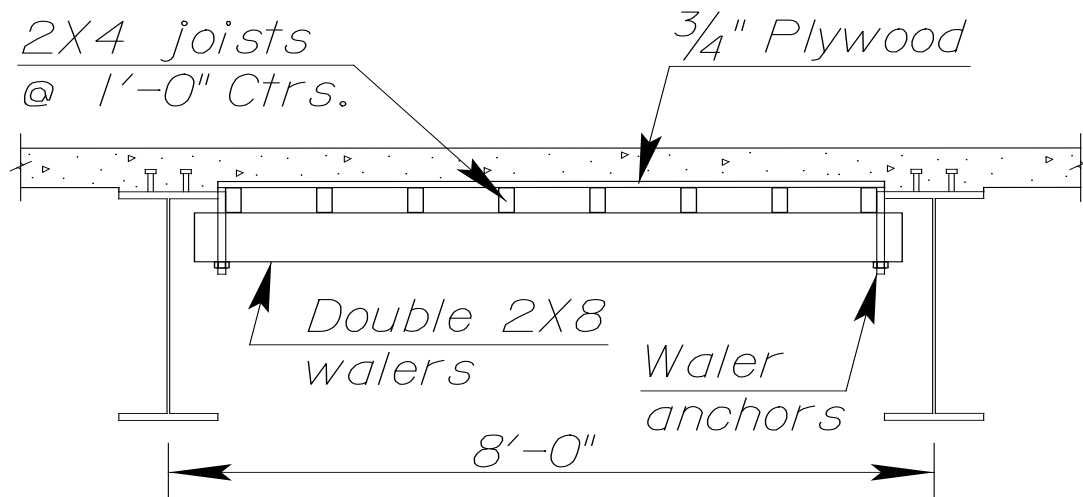

Check 3/4" Plywood deck form

Given: 9" deck, 50 psf Live Load
Supported at 12" centers

Dead load:

deck 0.75' x 160 pcf = 120 psf

plywood (Table 4-3, ACI-SP4) = 2.2 psf

Live load: = 50.0 psf

Total load = 172.2 psf

From Table 7-2 6th Edition (ACI-SP4), for a load of 175 psf, $f = 1,545$ psi (four or more supports) & $\frac{3}{4}$ " plywood:

$$\begin{aligned} \text{Safe plywood support spacing} &= 20" \text{ (strong way)} > 12" \text{ (ok)} \\ &\text{(ok)} \\ &= 14" \text{ (weak way)} > 12" \text{ (ok)} \end{aligned}$$

Note: For an explanation of strong way/weak way use of plywood, see Fig. 4-6, page 4-8 (ACI-SP4).

Check 2 x 4 deck joists

Given: Joists spaced at 1'-0" centers and supported at 4'-0" centers.

$$\begin{aligned} \text{Total load to joists (x 1' spac.)} &= 172.2 \text{ lbs/ft.} \\ \text{(from previous calculation)} & \\ \text{Weight of 2 x 4 joists (50 pcf)} &= \underline{1.8 \text{ lbs/ft.}} \\ \text{Total load} &= 174.0 \text{ lbs/ft.} \end{aligned}$$

Check bending:

$$\begin{aligned} \text{2 x 4 section properties:} \quad S &= 3.06 \text{ in.}^3 \\ I &= 5.35 \text{ in.}^4 \end{aligned}$$

$$M = wL^2/10 = 174.0 \text{ lbs/ft.} \times 12 \text{ in./ft.} \times (4')^2/10 = 3,341 \text{ in.-lb.}$$

$$f = M/S = 3,341 \text{ in.-lb.} / 3.06 \text{ in.}^3 = 1,092 \text{ psi} < 1,200 \text{ psi (ok)}$$

Check deflection: (allowable = $48"/360 = 1/8"$)

(Note: When checking allowable deflections, do not include live load.)

Therefore, $w = 174.0 \text{ lbs/ft.} - 50 \text{ lbs/ft.} = 124 \text{ lbs/ft.}$

$$\Delta = wL^4/145 EI = \frac{124 \text{ lbs/ft.}(48")^4}{(12)145(1.5 \times 10^6 \text{ psi})(5.35 \text{ in.}^4)} = 0.047" < 1/8" \text{ (ok)}$$

Codes (not AASHTO) limit deflection to 1/360 of span as a tolerance for appearance and having a workable structure (see pg. 6-5 ACI Formwork). On a deck, deflection would have little adverse effect unless it affected the finishing screed.

Check horizontal shear: $H = 3V/2bh$

$$V = 0.6 wL \text{ (for uniformly loaded)}$$

$$L = 4' - 0'' \quad w = 174.0 \text{ lbs/ft.}$$

$$V = 417.6 \text{ lbs.}$$

$$H = \frac{3(417.6)}{2(1.5)(3.5)} = 119 \text{ psi} < 120 \text{ psi (ok)}$$

Check bearing:

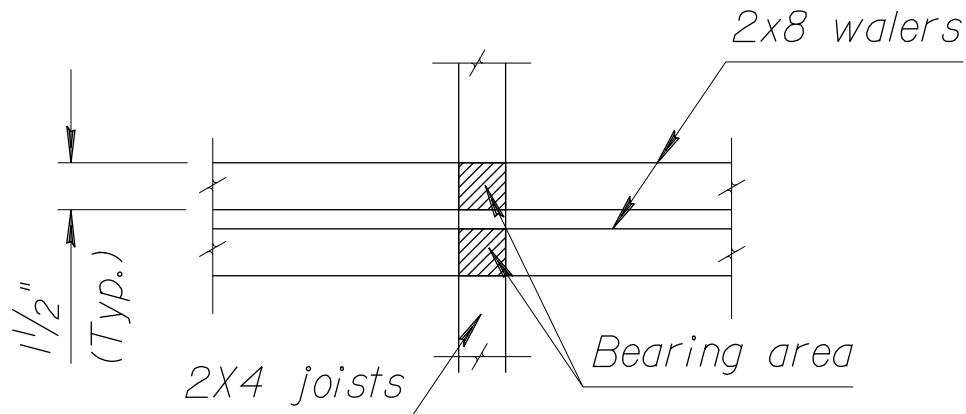

$$\text{Bearing Length} = 1 \frac{1}{2}'' + 1 \frac{1}{2}''$$

$$L = 3'' < 6''$$

Referencing Section 5.4.1.3 Compression Perpendicular to Grain

$$\text{Factor} = \frac{L + 3/8}{L} = \frac{3 + 3/8}{3} = 1.125$$

$$\text{Reaction} = 1.1 wL = 1.1 (174.0 \text{ lbs/ft.})(4.0) = 765.6 \text{ lbs.}$$

$$\text{Area} = (1.5)^2 \times 2 = 4.5 \text{ in.}^2$$

$$\text{Bearing stress: } 765.6 \text{ lbs.} / 4.5 \text{ in.}^2 = 170 \text{ psi} < 450 \text{ psi (ok)}$$

$$400(1.125) = 450 \text{ psi}$$

Check 2 x 4 deck joists by Tables

From Dayton-Superior Formbook (pg. 8), (also see Table 7.5.2 ACI Formwork);

For $f = 1,500 \text{ psi}$, load = 175 lbs/ft., 3 or more spans:

Maximum safe spacing of joists equals 56". To correct for values other than the tabular values (such as $f = 1,200 \text{ psi}$ instead of 1,500 psi), use the following method:

$$\text{Tabular values:} \quad L_1, f_1, w_1$$

$$\text{Actual values:} \quad L_2, f_2, w_2$$

$$M = wL^2/8; f = M / S; \quad f_1 = w_1 L_1^2 / 8S$$

$$f_2 = w_2 L_2^2 / 8S$$

$$f_1 / f_2 = (w_1 L_1^2 / 8S) / (w_2 L_2^2 / 8S) = w_1 L_1^2 / w_2 L_2^2$$

$$\text{solving for } L_2 = \sqrt{w_1 L_1^2 f_2 / w_2 f_1}$$

for $f_2 = 1,200$ psi;

$$L_2 = \sqrt{\frac{(56)^2 1,200}{1,500}} = 50.1" > 48" \text{ (ok)}$$

NOTE: When checking maximum formwork spacings using tables, the allowable bending, shear, and deflection values have been satisfied and therefore need not be checked.

Check double 2 x 8 walers

Note: Overhang brackets, deck walers and hangers on girder bridges are defined as falsework members. However, these members are subject to direct and nonredundant distribution of loads and therefore it is KDOT's practice to design these members using the more conservative formwork live loading.

Reaction of 2 x 4 joist on walers: (See AISC Beam Diagrams for reaction formulas.)

$$R = 1.1 wL = 1.1 \times 174.0 \text{ lbs/ft.} \times 4.0' = 765.6 \text{ lbs.}$$

The waler selfweight is 7.8 lbs/ft

Assume 2 x 4 joists are continuous over 3 supports and load 2 x 8 walers as a uniform load. 2 x 4 joists are at 1'-0" centers therefore uniform load = 765.6 lbs/ft. + 7.8 lbs/ft. = 773.4 lbs/ft.

Beam spacing is 8'-0" centers, overhang supports subtract about 1'-0" from spacing, therefore, use span = 7'-0".

Simple beam moment = $wL^2/8$

2 x 8 section properties:	$S = 13.14 \text{ in.}^3$
Double 2 x 8:	$S = 26.28 \text{ in.}^3$

$$M = \frac{773.4 \times (7)^2}{8} = 4,737 \text{ ft.-lbs.}$$

$$f = 4,737 \text{ ft.-lbs.}(12)/26.28 \text{ in.}^3 \\ = 2,163 \text{ psi} \gg 1,200 \text{ psi (NG) OVERSTRESS}$$

(At this point, the Contractor was contacted and told that the double 2 x 8 walers at 4'-0" centers were unacceptable.)

Note of Caution: Falsework reviewers should not accept Contractor's arguments concerning falsework if the analysis indicates that the members would be excessively overstressed. In this case, the Contractor agreed to reduce the waler spacing to 3'-0".

$$R = 1.1 wL = 1.1(174.0 / \text{ft.})(3') = 574.2 \text{ lbs.}$$

$$f = M/S = \frac{574.2 \text{ lbs.} \times (7')^2 \times 12}{8 \times 26.28 \text{ in.}^3} \\ = 1,606 \text{ (high, but probably ok)}$$

Contractor indicated he would use #2 yellow pine. We assumed he would have good walers.

Check double 2 x 8 walers by Tables

Reference Dayton-Superior Forming Handbook (pg. 9):

For load of 600 lbs./lin.-ft. and $f = 1,500$ psi, the maximum support spacing for double 2 x 8 walers is 79".

Adjust the tabular support spacing as found above for $w = 574.2$ lbs./lin. ft., and $f = 1,606$ psi:

$$L_2 = \sqrt{\frac{L^2 f_2 w_1}{w_2 f_1}} = \sqrt{\frac{(79)^2 1,606(600)}{574.2(1,500)}} \\ = 83.56" \text{ (approx. } = 84" \text{ used; ok)}$$

Check horizontal shear: $H = 3V/2bh$

$$V = wL/2$$

$$L = 7'-0" \quad w = 574.2 \text{ lbs./ft.}$$

$$V = 2,010 \text{ lbs.} / 2 \text{ walers} = 1,005 \text{ lbs.}$$

$$H = \frac{3(1,005)}{2(1.5)(7.25)} = 139 \text{ psi} > 120 \text{ psi (12\% overstress, say okay)}$$

Check bearing: (Assume 3½" diameter bracket)

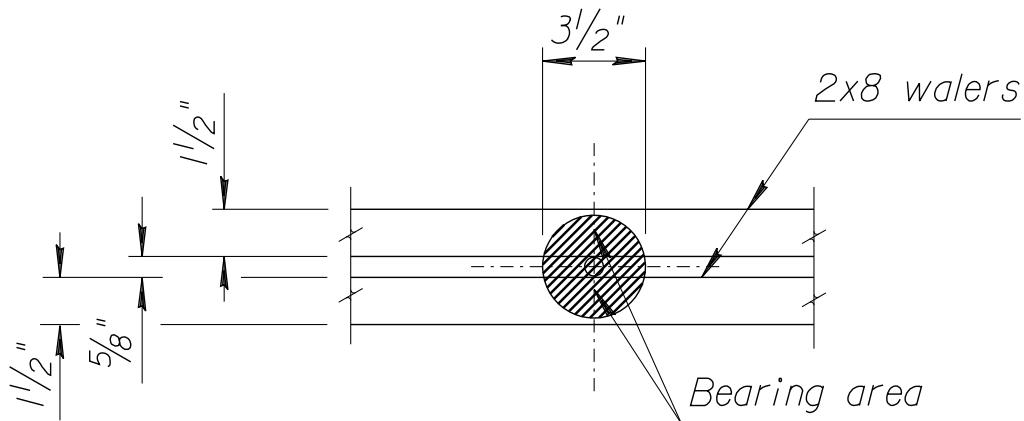

$$\begin{aligned}
 \text{Bearing area} &= \pi d^2/4 - (d \times 5/8") \\
 &= \pi (3.5)^2/4 - (3.5 \times 5/8") \\
 &= 7.43 \text{ in.}^2
 \end{aligned}$$

Since bearing length < 6" and assume bearing not nearer than 3" to end of member, bearing allowable may be increased by $(L+3/8")/L$.

$$\begin{aligned}
 L &= \text{Length of bearing} \\
 &= (3.5 + 3/8)/3.5 = 1.11
 \end{aligned}$$

$$\text{Allowable bearing} = 1.11 \times 400 = 444 \text{ psi}$$

$$\text{Actual bearing} = 2,010 \text{ lbs.} / 7.43^2 = 270.5 < 444 \text{ psi (ok)}$$

Waler Hangers

$$\text{Reaction (simple beam)} = wL/2$$

$$R = 574.2 \text{ lb./ft.} \times 7' / 2 = 2,010 \text{ lbs.}$$

Contractor should indicate type of hanger used. Most hangers will accommodate this load.

Overhang Brackets

Overhang brackets are difficult to check. The shapes are indeterminate and are usually selected for a safe working load stipulated by the fabricator. A catalog print of the bracket is essential and a check should be refused until one is received.

Things to watch:

1. Is bracket being used within the dimensions shown? Extensions are available from manufacturer. Bracket may also be “blocked out” with a “2 x” piece in which case an end cantilever may result.
2. For a steel beam or girder the telescoping arm should kick into the bottom flange if possible. There have been problems with bending webs resulting in finishing problems on some steel bridges.
3. Check the location of the rail for the finishing screed. It will usually be carried by the overhang bracket.

Check load on bracket. Brackets are spaced the same as walers because of support hangers. (For this example, bracket spacing is at 3'-0" centers).

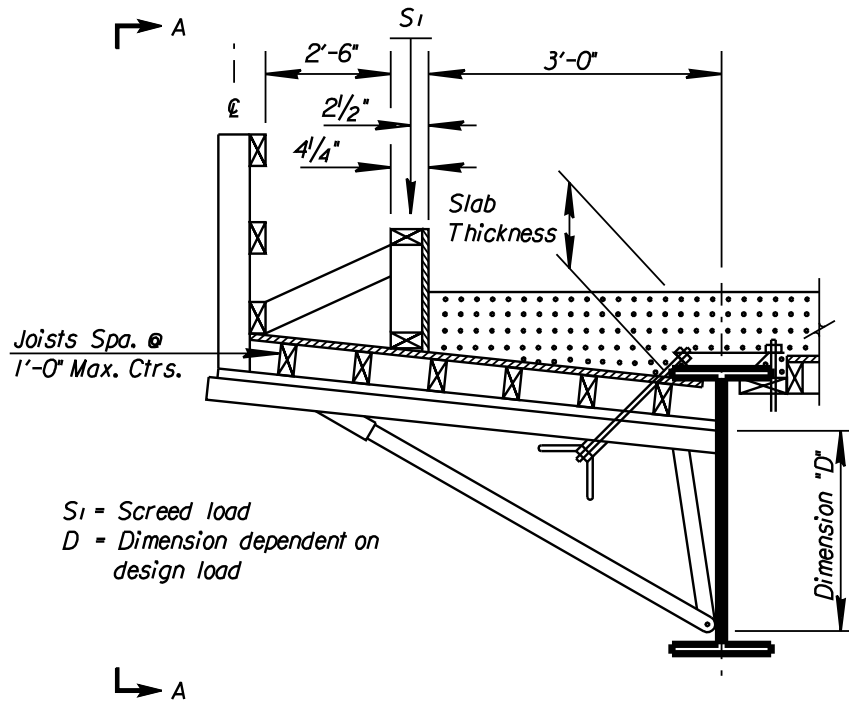

TYPICAL OVERHANG BRACKET

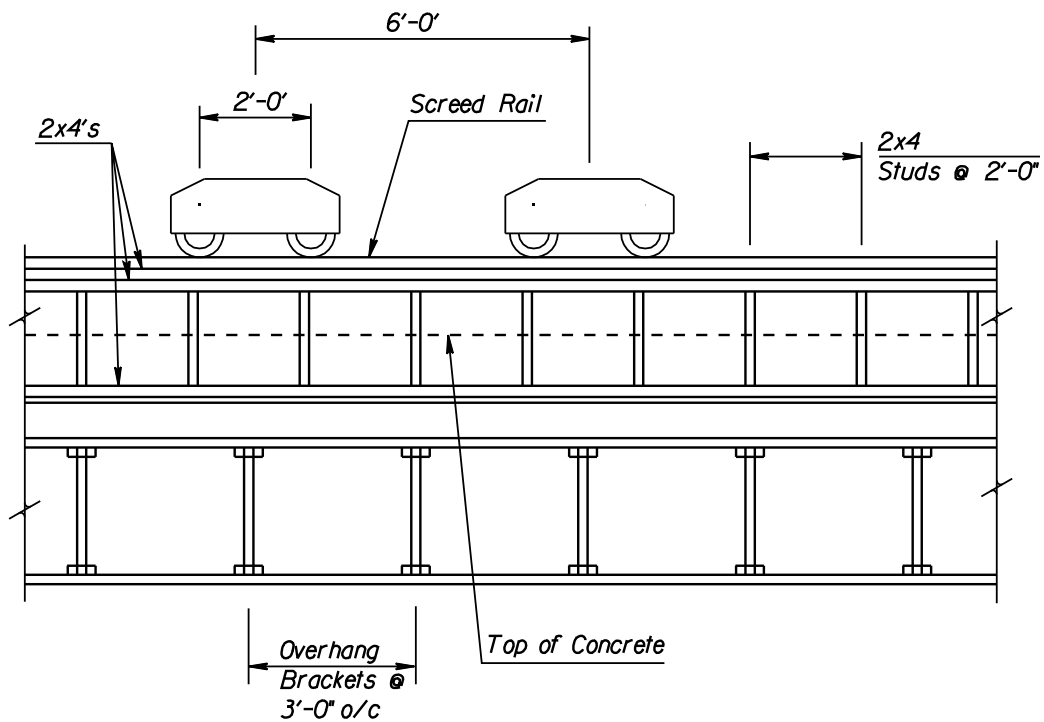

VIEW A-A

Finishing Machine:

Finishers generally run on at least 4 supports called “bogies.” A bogie has 2 wheels and travels over a rail supported by the overhang brackets. Weights of finishers vary from 2,000 to 6,000 lbs. The Contractor should supply finisher weight information.

For this example, assume the screed load is 5,700 lbs. Add additional weight for the power unit end of finisher which is heavier than the idler end. Assume 75 lb. per wheel for the power unit. Also include weight of a 200 lb. operator.

$$\begin{aligned}
 \text{Total load per wheel} &= 5,700 \text{ lbs.}/8 \text{ wheels} = 712.5 \text{ lbs./wheel} \\
 \text{Add weight of 200 lb. operator} &= 200 \text{ lb.}/4 = 25.0 \text{ lbs./wheel} \\
 \text{Add weight of power unit} &= \underline{75.0 \text{ lbs./wheel}} \\
 \text{Total Finisher weight per wheel} &= 812.5 \text{ lbs.} \\
 &\text{(Use 815 lbs./wheel)}
 \end{aligned}$$

Compute wheel load per bracket using simple beam distribution:

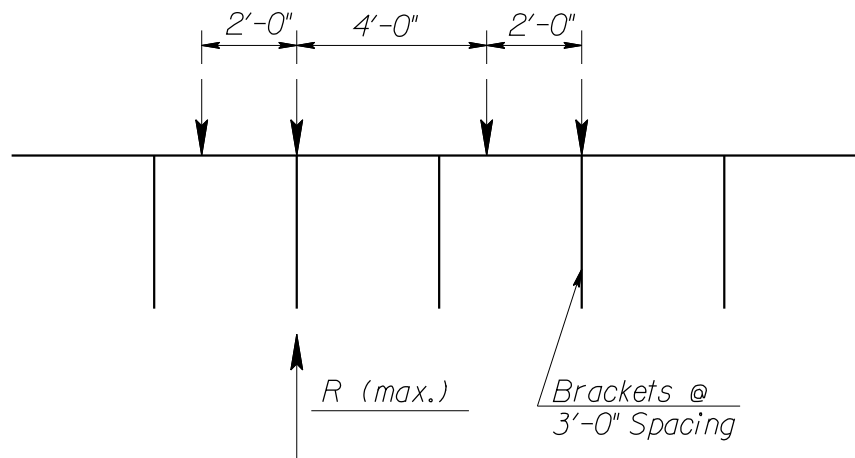

$$R(\text{max}) = 815 \text{ lbs.} + 815 \text{ lbs.}/3 = 1,087 \text{ lbs./bracket (Screed Load)}$$

Compute dead load to brackets:

(P1) Concrete - $(0.75')(3')(3')(160 \text{ lbs./ft.}^3)$	= 1,080 lbs.
(P5) Bracket	= 50 lbs.
(P4) Forms - $(5.85')(3') \times 5 \text{ lbs./ft.}^2$	= <u>88 lbs.</u>
Total Dead Load	= 1,218 lbs.

Compute live load to brackets:

On concrete: $50 \text{ lbs./ft.}^2(3')(3')$	= 450 lbs.
On walkway: $50 \text{ lbs./ft.}^2(2'-6'')(3')$	= <u>375 lbs.</u>
(P2) Total Live Load	= 825 lbs.

Total maximum load to bracket:

$$\begin{aligned} (P1+P5+P4) \text{ Dead Load} &= 1,218 \text{ lbs.} \\ (P2) \text{ Live Load} &= 825 \text{ lbs.} \\ (P3) \text{ Screed Load} &= \underline{1,087 \text{ lbs.}} \\ &3,130 \text{ lbs.} \end{aligned}$$

The bracket is rated by the manufacturer at 3,600 lbs., therefore, it is sufficient.
Approximate check of overhang bracket:

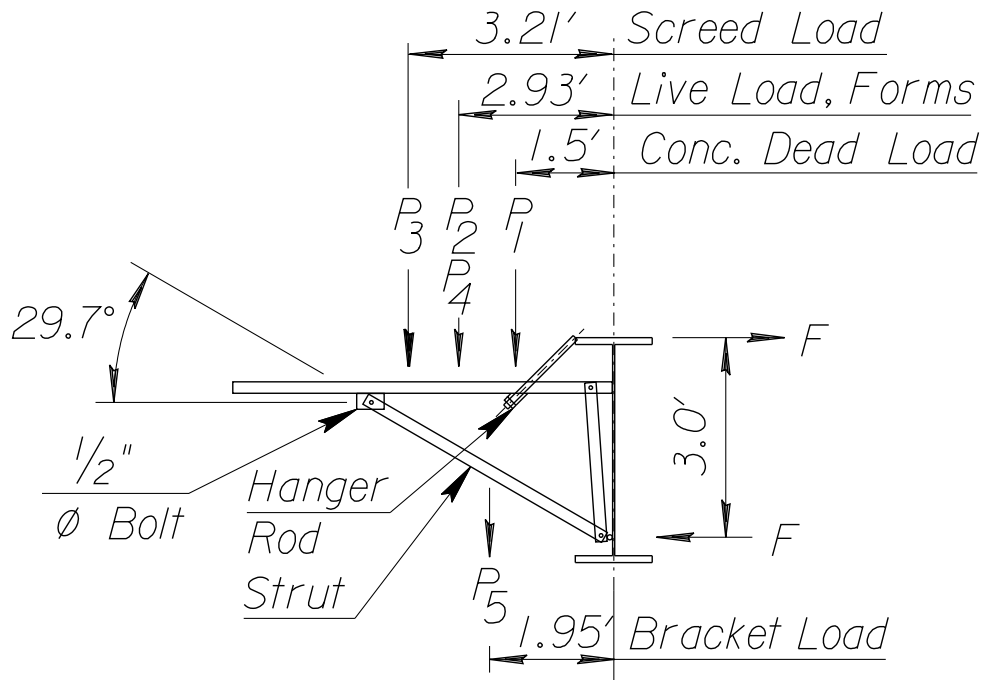

$$3.0'(F) = 3.21'(1,087) + 2.93'(913) + 1.5(1,080) + 1.95'(50)$$

$$F = 2,627 \text{ lbs.}$$

$$\text{Force in Strut: } \frac{2,627 \text{ lbs.}}{\cos 29.7^\circ} = 3,025 \text{ lbs.}$$

Check 1/2" diameter bolt (double shear): (Assume A307 bolt)

$$\frac{3,025}{2(0.20 \text{ in.}^2)} = 7,563 \text{ psi} < 11,000 \text{ psi allowed (ok)}$$

Check hanger rod:

$$\text{Total load on bracket} = 3,130 \text{ lbs.}$$

$$\frac{3,130 \text{ lbs.}}{\cos 45^\circ} = 4,426 \text{ lbs.} < 6,000 \text{ lbs. allowed per Manufacturers Specifications}$$

Figure 5.8-6(a) Finishing Machine Sketch

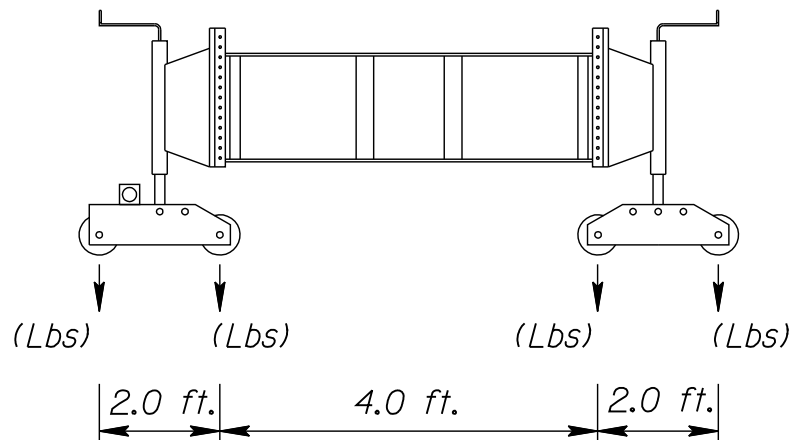

ASSUMED FINISHING MACHINE
VALUES LOADING DIAGRAM

Note: The maximum allowable rotation in the exterior girder was calculated assuming screed wheel loads as shown and placed 3" beyond the outside of the deck. The maximum overhang bracket spacing was assumed at ft. When the actual screed loadings are greater than these assumed loads, the Contractor shall submit to the Engineer design calculations for a torsional analysis of the exterior girder and bracing using the actual screed loads. The design calculations shall bear the seal of a licensed Professional Engineer.

The above screed loading sketch is to be placed on a "Miscellaneous Details" sheet on all steel girder bridge plans. The Bridge Designer will estimate the maximum screed loads allowable based on the torsional capacity of the beam and the screed configuration shown above.

The following section ([1.a Check Torsional Stresses in Exterior Girder](#)) presents a method for estimating torsional beam capacity. Another method that more accurately reflects the response of the girder has recently been developed under the K-Tran Project (KU-96-3) entitled "Torsion of Exterior Girders of a Steel Girder Bridge During Concrete Deck Placement - A Design Aid". See [3.2.3 Welded Steel Girder and Beam Design](#) for additional discussion on torsion of exterior girders.

1.a Check Torsional Stresses in Exterior Girder

(Ref. "Design for Concrete Deck Overhang Loads" AISC Marketing, Inc., June 18, 1990 (Final Report))

Flanges in compression shall be checked to limit both permanent deformations and for adequate ultimate strength. Flanges in tension are checked to limit permanent deformations only.

In the design phase, the Engineer will need to estimate the maximum screed wheel loads, wheel spacing and overhang cantilever bracket spacing. These variables are dependent upon the type of screed and finishing equipment used, width and skew of the bridge, and length of overhang.

Weights of finishing machines may be obtained from their respective catalogue clips. Overhang bracket spacings are normally in the 3 to 4 foot range.

For this example, assume a 44'-0" roadway with a Gomaco C-450 finishing machine. Compute weight as follows:

Gomaco C-450:	24' basic unit	=	4,200 lbs.
	+ 2-12' extensions	=	<u>1,500 lbs.</u>
			5,700 lbs.

5,700 lbs./8 wheels	=	712.5 lbs./wheel
+ 200 lb. operator/4 wheels	=	50.0 lbs./wheel
+ Power Unit end	=	<u>75.0 lbs./wheel</u>
		837.5 (Use 850 lbs./wheel)

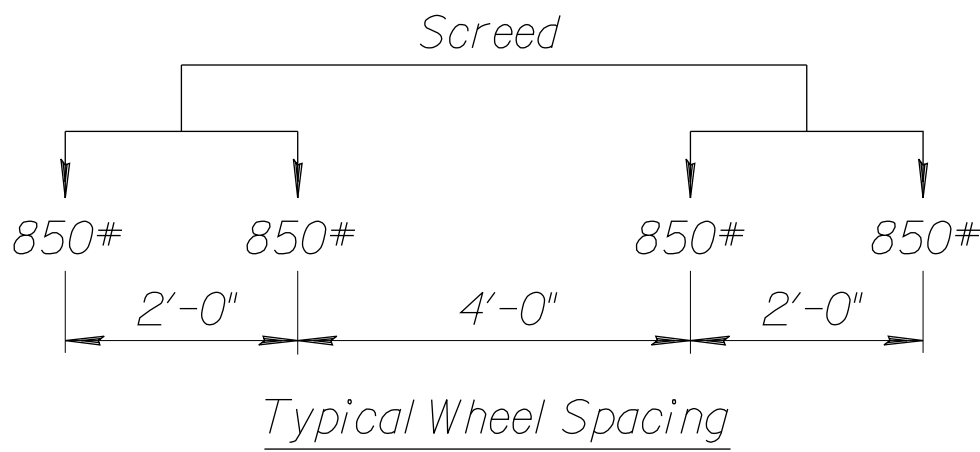

Note: Using TAEG Software, the bridge designer shall show on the plans the maximum screed load allowable based on the torsional capacity of the beam. (Max. 1,500 lbs./wheel) See [Figure 5.8-6\(a\) Finishing Machine Sketch](#).

Assume a 3 foot overhang bracket spacing with 21'-0" diaphragm spacing.
 Girder and overhang details are as follows:

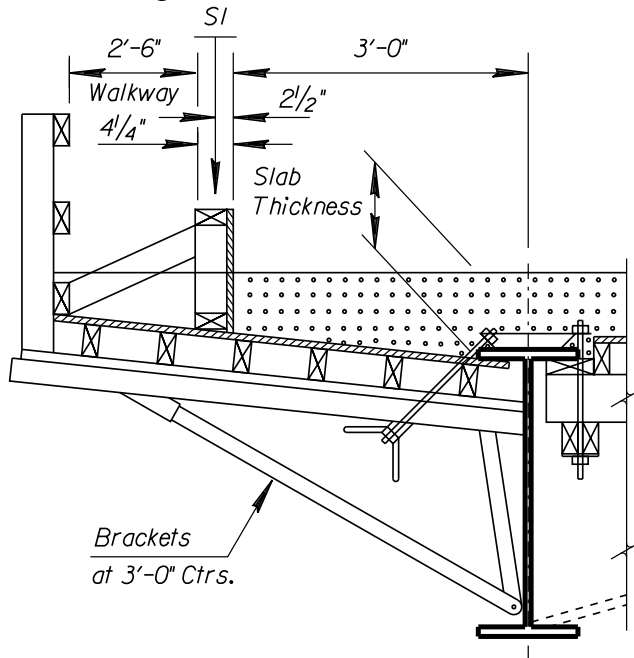

Girder: $F_y = 36 \text{ KSI}$
 Top Flange = 1"x12"
 Web = $\frac{3}{8}$ "x51.5"
 Btm. Flange = $1\frac{1}{2}$ "x16"

Construction Live Load of
 50 Lbs./Ft.² on Walkway
 and slab

Schematic of exterior girder:

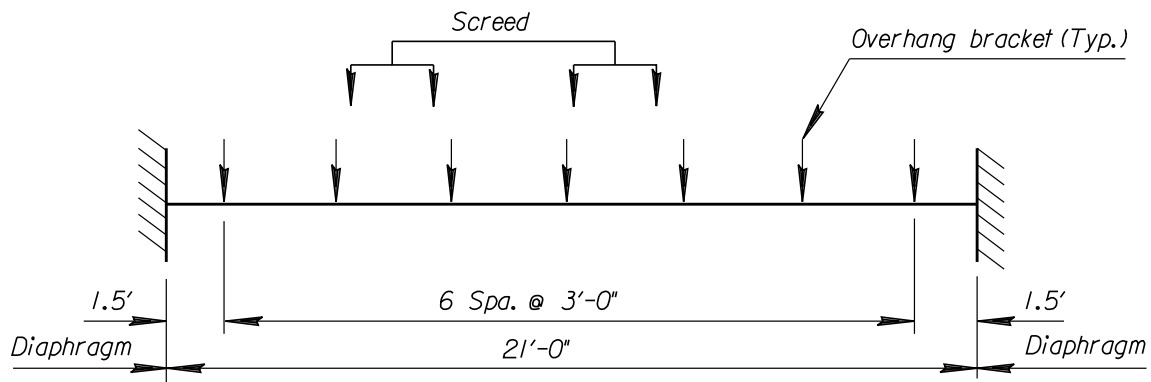

Torsional loads may be computed using the method described in the AISC Marketing Report or manually as follows:

Compute torsional moments due to screed machine:

Screed load should be moved along girder in between diaphragms to obtain the largest torsional moments.

Distribute screed load to brackets (vertical load):

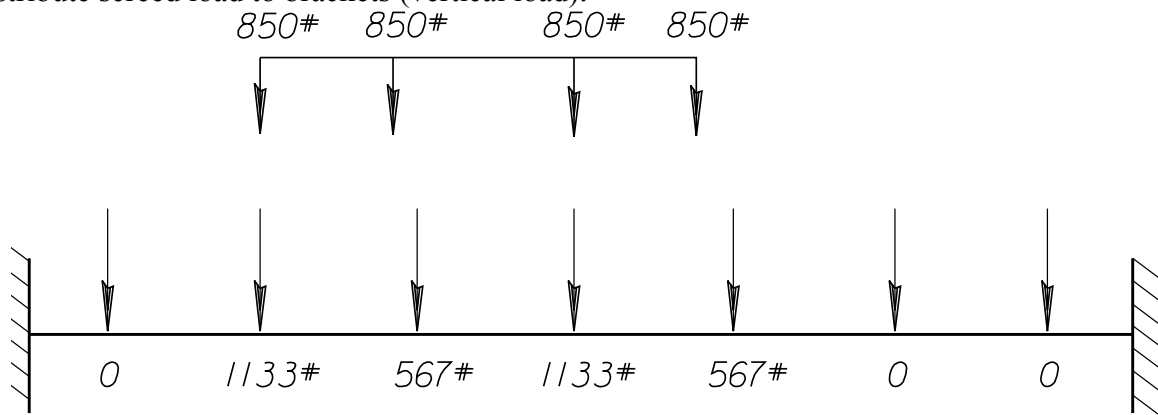

Compute force to flange:

Screed load x moment arm/girder depth (center of flanges)

$$(1133\#)(3.21') / (52.75"/12) = 827 \text{ lbs.}$$

$$(567\#)(3.21') / (52.75"/12) = 414 \text{ lbs.}$$

Schematic of forces on flange:

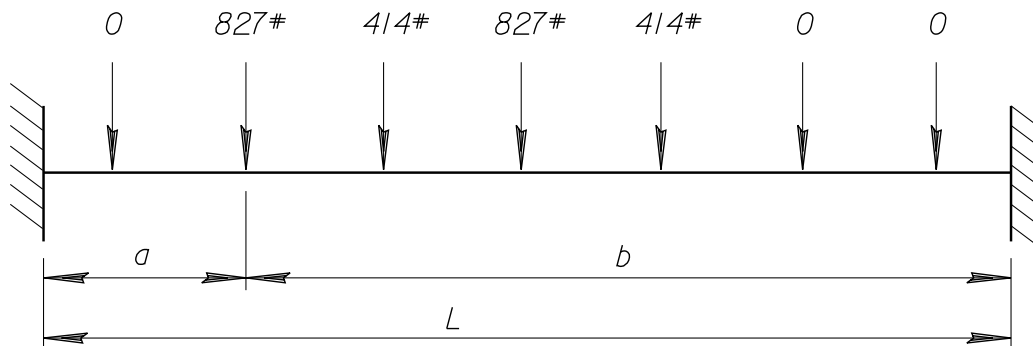

Compute shear: $V = Pp^2(3a + b)/L^3$

$$827(16.5)^2 / (21)^3 \times [3(4.5) + 16.5] = 729 \text{ lbs.}$$

(repeat for the other 3 loads) = 293

= 414

= 121

1,557 lbs.

Compute fixed end moment: $M = Pab^2/L^2$

$L = 21'$

$827(4.5')(16.5)^2/(441)$

$= 2,297 \text{ ft.-lbs.}$

(repeat for the other 3 loads)

$= 1,283$

$= 2,171$

$= \underline{713}$

$6,464 \text{ ft.-lbs.}$

Maximum torsional shears and moments due to screed machine:

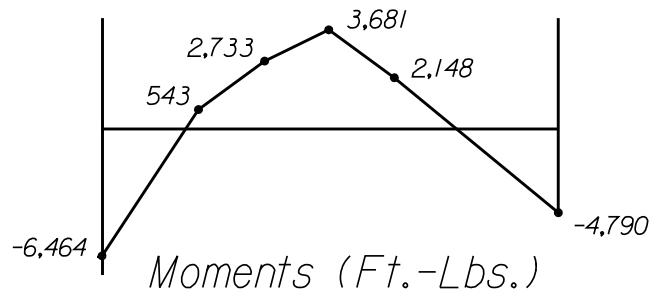
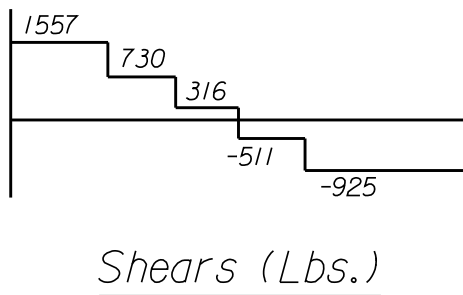

The maximum torsional moment due to the screed load

at the diaphragms: $(M_{fw})_{max} = - 6,464 \text{ ft.-lbs.}$

at the center of beam: $(M+)_{max} = +3,681 \text{ ft.-lbs.}$

Compute torsional moment due to uniform dead and live loads:

Lateral Pressure on Form:

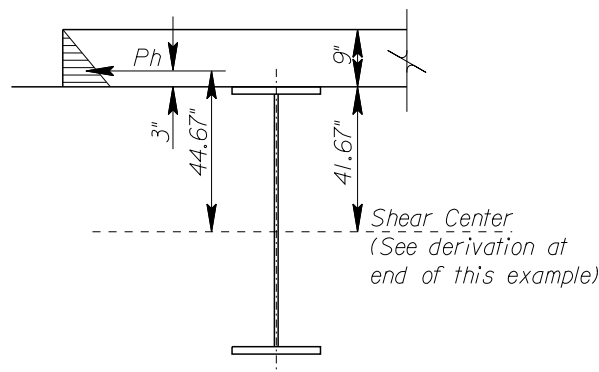

Horizontal fluid pressure:

$Q = 85 \text{ lbs./ft.}^3$

$P_n = (85 \text{ lbs./ft.}^3)((0.75)^2/2) = 23.9 \text{ lbs./ft.}$

Lateral Pressure Moment = 23.9 lbs./ft. (3') x 44.67"/12 = 267 ft.-lb.

Concrete (P1):	1,080 lbs. x 1.5'	= 1,620 ft.-lbs.
Forms (P4):	88 lbs. x 2.93'	= 258
LL on Conc. (P2):	450 lbs. x 1.5'	= 675
LL on Walkway (P2):	375 lbs. x 4.6'	= 1,725
Bracket (P5):	50 lbs. x 1.95'	= <u>98</u>
Total dead load torsional moment per bracket		= 4,376 ft.-lbs.

Lateral Force to flange = 4,376 ft.-lbs. / 4.40 ft. = 995 lbs.

Calculate fixed end moments: $M = Pab^2/L^2$ $L = 21'$

$$995 \text{ lbs.} (1.5') (19.5')^2 / (441) = -1,287 \text{ ft.-lbs.}$$

(repeat for the other 6 loads)	=	-2,764
	=	-3,084
	=	-2,612
	=	-1,713
	=	- 754
	=	<u>- 99</u>
FEM		-12,313 ft.-lbs.

Compute Max. Shear: 995 lbs. x 7 brackets / 2 = 3,483 lbs.

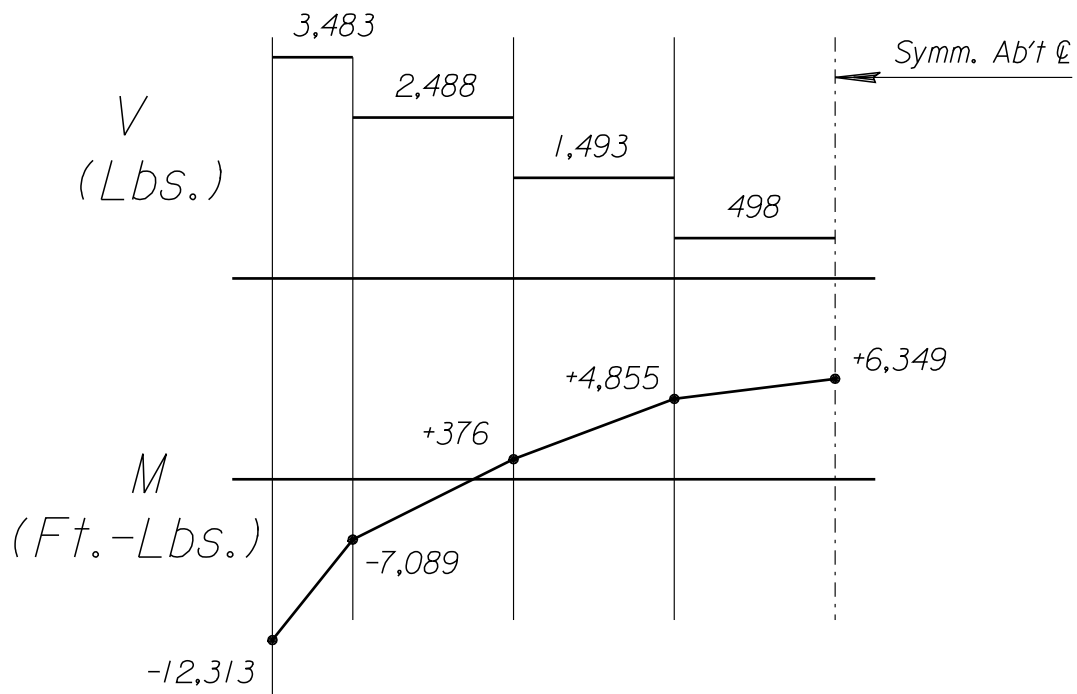

The maximum torsional moments due to uniform dead and live loads
 at diaphragms: $(M_{fw})_{max} = -12,313$ ft.-lbs.
 at center of beam: $(M+)_{max} = 6,349$ ft.-lbs.

Apply a load factor of 1.3 to both dead and live loadings and screed load:

Total $(M_{fw})_{max}$ (@ diaph.) = $[-6,464 + (-12,313)] 1.3 = -24,410$ ft.-lbs.
 (AISC Tables = -24,146 ft.-lbs.)

Total $(M+)_{max}$ (@ centerline) = $[+3,681 + 6,349] 1.3 = +13,039$ ft.-lbs.
 (AISC Tables = +13,402 ft.-lbs.)

(Note: AISC Tables and “Torsion” spreadsheet approximates the moment at centerline as 0.53 x (DL + LL)FEM and 0.60 x screed load FEM.)

1) Check yielding in top flange at Diaphragm.

a) Flange tip stresses: $(M_{fw})_{max} = -24,410$ ft.-lbs. = -292.9 K-in.

$$\sigma_w = \frac{6(M_{fw})_{max}}{t_f b_f^2}$$

$$\sigma_w = \frac{6(-292.9 \text{ K-in.})}{1(12)^2} = 12.20 \text{ ksi}$$

b) Max. longitudinal bending stress due to 1.3 x non-composite dead load.

Calculate the maximum factored non-composite dead-load stress at the diaphragm considering the deck-casting sequence.

For this example, assume

$$\sigma_b = 13.0 \text{ ksi (non-composite dead load stress x 1.3)}$$

Total stress =

$$\sigma_w + \sigma_b = 12.20 \text{ ksi} + 13.0 \text{ ksi} = 25.2 \text{ ksi} < 36 \text{ ksi (OK)}$$

2) Check ultimate strength of the top flange in-between cross-frames.

a) Since the top flange is subject to an axial compressive force and lateral bending moments, check the ultimate strength of the flange as an equivalent beam-column using the following interaction equation.

$$\frac{P}{0.85(A_s)F_{cr}} + \frac{M(C_m)}{M_u(1 - P/A_s F_e)} \leq 1.0$$

$$A_s = 1"(12") = 12.0 \text{ in.}^2$$

$$P = 13 \text{ ksi}(12")(1") = 156 \text{ K}$$

$$M = 13,039 \text{ ft.-lbs.} = 13.04 \text{ ft.-K (Total (M+)_{max} @ centerline)}$$

$$C_m = 0.85$$

$$F_{cr} = F_y \left[1 - \frac{F_y}{4\pi^2 E} \left(\frac{KL}{r} \right)^2 \right]$$

$$K = 1, \quad F_y = 36 \text{ ksi}, \quad E = 29,000 \text{ ksi}$$

$$r = \sqrt{I_{yf} / A_f} = [((1)(12)^3 / 12) / 12]^{1/2} = 3.46''$$

$$KL/r = 1(21)(12)/3.46'' = 72.8 < 126.1$$

(AASHTO Table 10.32.1A)

Substituting gives $F_{cr} = 30.0 \text{ ksi}$

$$F_e = \frac{E\pi^2}{\left(\frac{KL}{r}\right)^2} = 54 \text{ ksi}$$

$$J = b_f t^3 / 3 = 12(1)^3 / 3 = 4.0 \text{ in.}^4$$

$$S_y = bd^2 / 6 = (1)(12)^2 / 6 = 24.0 \text{ in.}^4$$

$$Z = bd^2 / 4 = (1)(12)^2 / 4 = 36.0 \text{ in.}^4$$

$$M_p = F_y Z = 36 \text{ ksi}(36.0 \text{ in.}^4) / (12) = 108 \text{ ft.-K}$$

$$M_r = F_y S = 36 \text{ ksi}(24.0 \text{ in.}^4) / (12) = 72 \text{ ft.-K}$$

Compute Mu: (Ref. AISC LRFD Manual, 1st Ed., Appendix F)

M_u is dependent upon the cross-frame spacing (d). Need to determine what unbraced length will allow the section to reach full plastic moment (L_p) and at what unbraced length the section is controlled by elastic lateral-torsional buckling (L_T).

$$L_p = \frac{3,750 r \sqrt{JA_f}}{M_p} \text{ (if } d < L_p \text{ then } M_u = M_p)$$

$$L_r = \frac{57,000 r \sqrt{JA_f}}{M_r} \left(\text{if } d > L_r \text{ then } M_u = M_p = \frac{\pi C_b \sqrt{E I_{yf} GJ}}{Kd} \right)$$

If the cross frame spacing (d) falls in between L_p and L_r , M_u is computed from the following straight-line approximation:

$$M_u = C_b \left[M_p - (M_p - M_r) \left(\frac{d - L_p}{L_r - L_p} \right) \right] \leq M_p$$

$C_b = 1$ (conservative) Ref. AASHTO ART 10.48.4.1

$$L_p = \frac{3,750(3.46)\sqrt{(4.0)(12.0)}}{(108)(12)(12)} = 5.78 \text{ ft.}$$

$$L_r = \frac{57,000(3.46)\sqrt{(4.0)(12.0)}}{(72)(12)(12)} = 131.8 \text{ ft.}$$

$d = 21 \text{ ft.} : L_p < d < L_r$ thus

$$M_u = 1.0 \left[108 - (108 - 72) \left(\frac{21.0 - 5.78}{131.8 - 5.78} \right) \right] \leq M_p$$

$$M_u = 103.7 \text{ ft.-K}$$

therefore, solving the interaction equation:

$$\frac{156^K}{0.85(12.0 \text{ in}^2)(30.0 \text{ ksi})} + \frac{13.04 \text{ ft.-K}}{103.7 \text{ ft.-K} \left(1 - \frac{156.0}{12.0 \text{ in}^2 \cdot 54.0 \text{ ksi}} \right)} =$$

$$0.51 + 0.17 = 0.68 < 1 \text{ (OK)}$$

Estimate Angle of Rotation

The beam fixity at the diaphragms is somewhere between a fixed and pinned condition. Compute the angle of rotation for both end conditions and average the results. The average angle of rotation should be less than 1 (one) degree.

(ref. "Torsional Analysis of Steel Members" AISC, 1983.)

Convert point loaded torsional moments to a uniform torsional moment.

Screed Machine:	850 lbs./wheel x 4 wheels x 3.21'	= 10,914 ft.-lbs.
Dead Loads:	4,376 ft.-lbs.	= <u>30,632 ft.-lbs.</u>
	Total	= 41,546 ft.-lbs.

$$m = \frac{41,546 \text{ ft.-lbs.}}{21.0'(1,000)} = 1.98 \text{ K-ft./ft.}$$

$$\phi = \frac{mLa}{2GJ} \left[\left(\frac{1 + \cosh(L/a)}{\sinh(L/a)} \right) \left(\cosh\left(\frac{Z}{a}\right) - 1.0 \right) + \left(\frac{Z}{a}\right) \left(1 - \frac{Z}{L} \right) - \sinh\left(\frac{Z}{a}\right) \right]$$

The above formula assumes a uniformly distributed torque on member with fixed ends.

L = 21'(12) = 252"	Z = distance from left end of the member to the
G = shear modulus of	transverse section under examination
elasticity of steel	= 252 / 2 = 126"
= 11,200 ksi	E = 29,000 ksi

$$J = \sum \frac{bt^3}{3} = \frac{(12)(1)^3 + 16(1.5)^3 + 51.5(0.375)^3}{3} = 22.9 \text{ in.}^4$$

$$a = \sqrt{EC_w / GJ} \quad E = 29,000 \text{ ksi}$$

$$a = 188 \text{ in.} \quad C_w = \frac{h^2 I_1 I_2}{I_y}$$

$$I_y = \frac{1(12)^3}{12} + \frac{1.5(16)^3}{12} + \frac{51.5(0.375)^3}{12}$$

$$= 144 + 512 + 0.23$$

$$I_y = 656.23 \text{ in.}^4$$

$$I_1 = 512 \text{ in.}^4$$

$$I_2 = 144 \text{ in.}^4$$

$$C_w = \frac{(52.75)^2 (512 \text{ in.}^4)(144 \text{ in.}^4)}{656.23 \text{ in.}^4}$$

$$= 312,623 \text{ in.}^6$$

$$\cosh x = \frac{1}{2} (e^x + e^{-x})$$

$$\sinh x = \frac{1}{2} (e^x - e^{-x})$$

Substituting yields: $\phi = 0.0022$ Radians = $0.13^\circ < 1^\circ$ (OK)

Pinned

Assume a uniformly distributed torque on member with pinned ends.

$$\phi = \frac{ma^2}{GJ} \left[\frac{L^2}{2a^2} \left(\frac{z}{L} - \frac{z^2}{L^2} \right) + \cosh \frac{z}{a} - \tanh \frac{L}{2a} \cdot \sinh \frac{z}{a} - 1.0 \right]$$

$$\tanh x = \frac{\sinh x}{\cosh x} \qquad L = 252'' \qquad z = L/2 = 126''$$

$$\qquad \qquad \qquad a = 188''$$

Substituting yields: $\phi = 0.272852(0.035539)$
 $= 0.00965$ Radians = 0.55°

Average angle of rotation = $\frac{0.13 + 0.55}{2} = 0.34^\circ < 1^\circ$ (ok)

The beam will twist around the shear center. The shear center for a symmetrical beam is located at the mid-depth of beam. The shear center for an unsymmetrical beam is located as follows:

- 1) Find the center of gravity of the beam about the X-axis.

1.5"(16")	x	0.75 = 18.0 in. ³
0.375"(51.5")	x	27.25 = 526.3
<u>1(12")</u>	x	53.50 = <u>642.0</u>
55.31 in. ²		1,186.3 in. ³

$$\bar{x} = 1,186.3 \text{ in.}^3 / 55.31 \text{ in.}^2 = 21.45 \text{ in.}$$

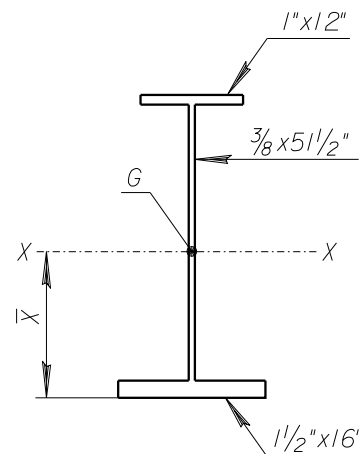

2) Find “e”, distance from center of gravity to shear center.

$$e = (c_1 I_1 - c_2 I_2) / I_y \quad [\text{if } 0.1 \leq I_1 / I_y \leq 0.9]$$

$$c_1 = 21.45'' - 0.75'' = 20.7 \text{ in.}$$

$$c_2 = 54'' - 21.45'' - 0.5'' = 32.05''$$

$$I_1 = bd^3/12 = 1.5(16)^3/12 = 512 \text{ in.}^4$$

$$I_2 = (1)(12)^3/12 = 144 \text{ in.}^4$$

$$I_y = I_1 + I_2 + 51.5''(0.375)^3/12 = (512 + 144 + 0.23) = 656.23 \text{ in.}^4$$

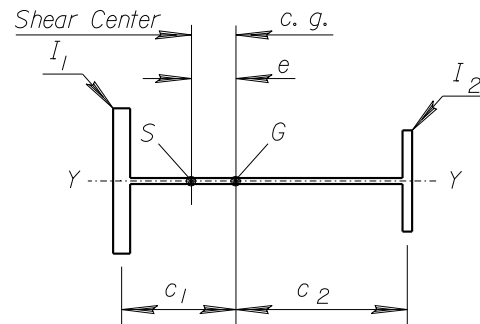

$$[I_1 / I_y = 0.78 \leq 0.9]$$

$$\text{therefore, } e = \frac{20.7(512) - 32.05(144)}{656.23} = 9.12''$$

To find the horizontal deflection (Δ) at the top of the girder, multiply the rotation (in radians) by the distance from the top of the girder to the shear center:

$$\begin{aligned} \text{Average angle of Rotation} &= [0.0022 \text{ (fixed)} + 0.00965 \text{ (pinned)}] / 2 \\ &= 0.006 \text{ Radians} \end{aligned}$$

$$\Delta h = 0.006 \text{ Radians} \times (32.55'' + 9.12'')$$

$$\Delta h = 0.25''$$

$$\Delta v = 0.006 \text{ Radians} \times 36''$$

$$= 0.22''$$

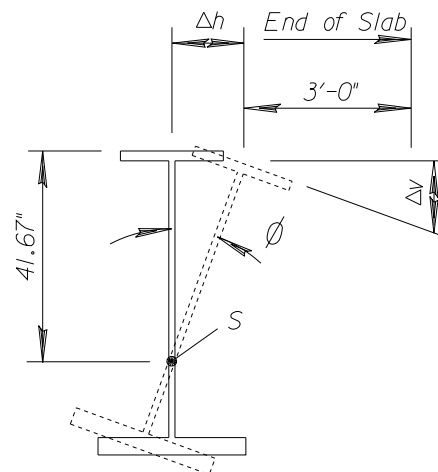

5.9 EXAMPLE NO. 2 - FALSEWORK CHECK FOR CONCRETE SLAB BRIDGE

Figure 5.9-1 Example of Falsework Submission

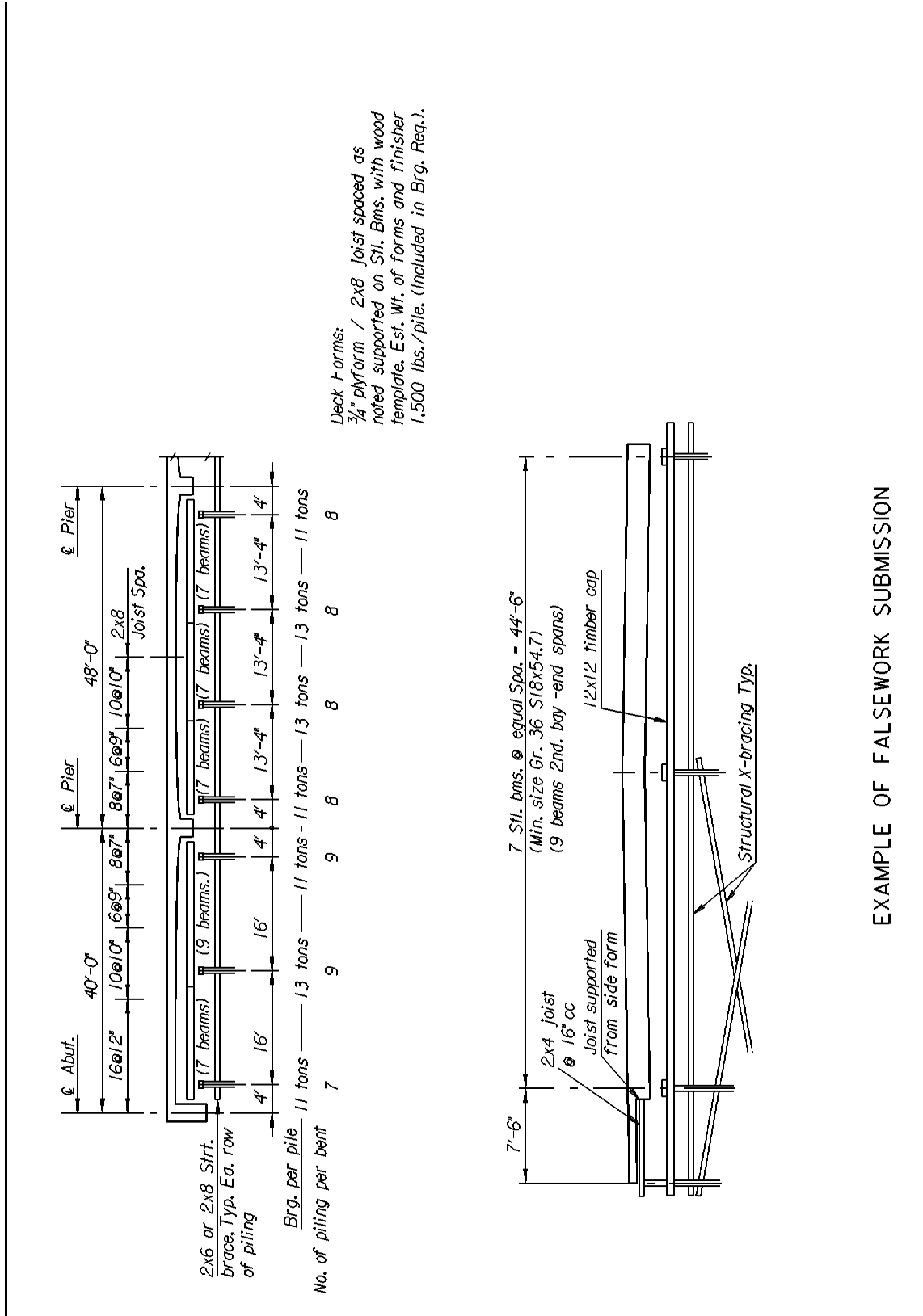

Bridge Information:

- 1) 40'-10" @ 48'-40" Reinforced Concrete Haunched Slab
- 2) 44'-0" Roadway
- 3) Slab thickness varies from 16" to 24⁷/₁₆"

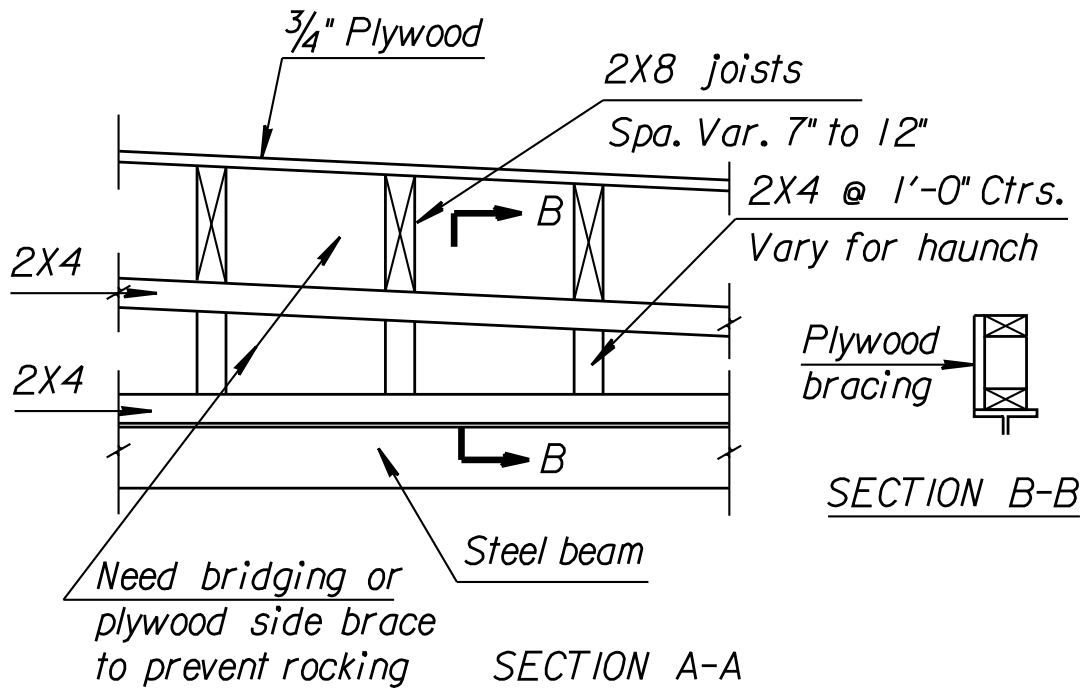
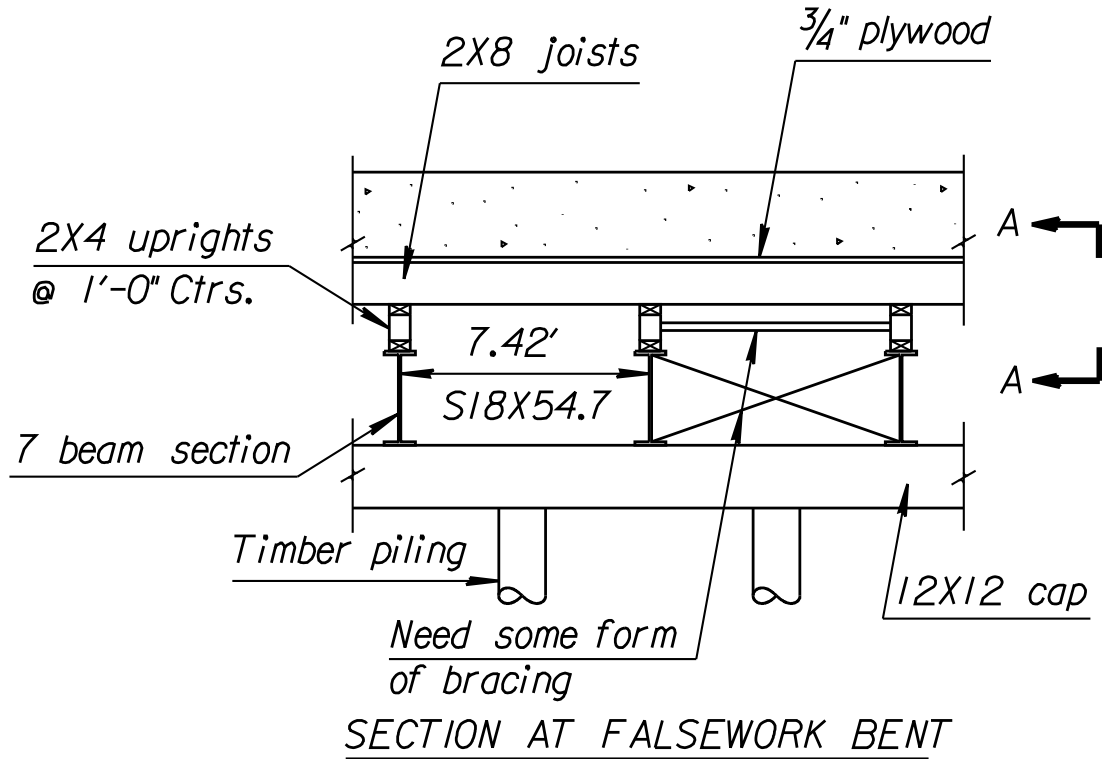

Check section in interior span that has the 7 beams supported by 8 piling with the joints spaced at 9" centers. (See Falsework sketch). Beams spaced at 7.42', piling spaced at 6.36'.

Check 3/4" Plywood Deck Form

$$\begin{array}{lcl}
 \text{Dead Load: (Assume slab depth as 1.86')} & & \\
 \text{deck } 1.86' \times 160 \text{ lbs./ft.}^3 & = & 297.6 \text{ psf} \\
 \text{plywood} & = & 2.2 \text{ psf} \\
 \text{Live Load:} & = & \underline{50.0 \text{ psf}} \\
 & & 349.8 \text{ psf}
 \end{array}$$

From ACI-SP4, Table 7-3, pg. 7-9, for a load of 400 psf:

$$\begin{array}{lcl}
 \text{Safe plywood support spacing} & = & 14" \text{ (strong way)} > 9" \text{ (ok)} \\
 & = & 10" \text{ (weak way)} > 9" \text{ (ok)}
 \end{array}$$

Check 2 x 8 Deck Joists

Given: Joists spaced at 9" centers and supported at 7.42' centers.

Total load to joists (from previous calculation) = 349.8 psf

$$\begin{array}{lcl}
 \text{Adjust for 9" spacing:} & 349.8 \times \frac{9}{12} & = 262.4 \text{ lbs/ft.} \\
 \text{Weight of 2 x 8 joists (50 pcf)} & & = \underline{3.8 \text{ lbs/ft.}} \\
 & & 266.2 \text{ lbs/ft.}
 \end{array}$$

Check bending:

$$\begin{array}{lcl}
 \text{2 x 8 section properties:} & S = 13.14 \text{ in.}^3 & \\
 \text{For continuous 3-span beam:} & &
 \end{array}$$

$$M = wL^2/10 = 266.2 \times (7.42)^2/10 = 1,465.6 \text{ ft.-lbs.}$$

$$f = M/S = 1,465.6 \text{ ft.-lbs.}(12)/13.14 \text{ in.}^3 = 1,338 \text{ psi (ok)}$$

Joints in 50 x 200 mm should be scabbed or lapped and secured.

Check Bearing:

2 x 8 joints bearing on 2 x 4. Bearing is perpendicular to grain.

$$\text{Reaction} = 1.1 wL = 1.1 (266.2 \text{ lbs./ft.}) 7.42' = 2,173 \text{ lbs.}$$

$$\text{Area} = 1.5 \times 3.5 = 5.25 \text{ in.}^2$$

The allowable bearing stress may be increased by a factor related to the bearing area (See Section 5.4.1.3):

$$\begin{aligned} (L + 3/8)/L &= (3.5 + 0.375)/3.5 \\ &= 1.11 \end{aligned}$$

Allowable bearing stress = 400 psi x 1.11 = 444 psi

Bearing stress: $2,173 \text{ lbs.} / 5.25 \text{ in.}^2 = 414 \text{ psi} < 444.0 \text{ psi (ok)}$

Check lateral support rules (see Section 5.4.1.1). For a 2 x 8, the depth to width ratio is 4. The ends shall be held in position and the member held in line. A 2 x 8 block between joists would be adequate at the support and nailing the plywood along the joists would hold it in line. Bracing and supporting makes the formwork more difficult to remove, but it should be specified.

Check bearing on horizontal 2 x 4's

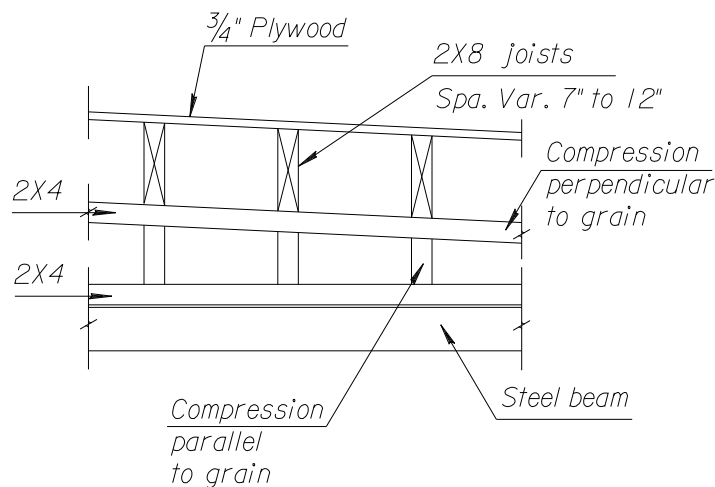

Haunch is formed in various ways. Some contractors use variable form as shown above. Another method is to step the longitudinal beams to more closely match the haunch.

Estimate load:

Concrete: $7.42' \times 1.86' \times 160 \text{ pcf} = 2,208 \text{ lbs/ft.}$

Plywood: $7.42' \times 2.2 \text{ lbs/ft.}^2 = 16 \text{ lbs/ft.}$

2x8's: $1.25 \text{ brds/ft.} \times 3.8 \text{ lbs/ft.} \times 7.42' = \underline{35 \text{ lbs./ft.}}$

2,259 lbs/ft.

Bearing area (2 x 4 upright) = $1.5" \times 3.5" = 5.25 \text{ in.}^2$

Bearing stress = $2,259 \text{ lbs/ft.} (1 \text{ ft.}) / 5.25 \text{ in.}^2 = 430 \text{ psi} < 444 \text{ psi}$

(ok)

Steel Beams

Steel beams may be old sections with an allowable stress of 18,000 psi. For old sections check AISC Book on "Iron and Steel Beams." Occasionally it is necessary to have field forces send in dimensions of the beam.

Beam: S 18 x 54.7 $S_x = 89.4 \text{ in.}^3$
 $I_x = 804 \text{ in.}^4$ $d = 18 \text{ in.}$

Dead Load:

Concrete	$[(1.33' + 2.04')/2](7.42')160 \text{ lbs/ft.}^3$	= 2,000 lbs/ft.
Plywood	$2.2 \text{ lbs/ft.} \times 7.42'$	= 16.3 lbs/ft.
2 x 8's	$1.25 \text{ brds/ft.} \times 3.8 \text{ lbs/ft.} \times 7.42'$	= 35.2 lbs/ft.
Formwork for parabolic haunch		5.5 lbs/ft.
Beam		<u>54.7 lbs/ft.</u>
	Total Dead Load	= 2,112 lbs/ft.

Uniform Live Load:

	$20 \text{ lbs/ft.}^2 \times 7.42'$	= 150 lbs./ft.
	75 lbs/lin.ft. (outside slab beam)	= 75 lbs./ft.

Concentrated Live Load:

	Finisher 4,000 lbs.	= 2,000 lbs.
	Operator	= 200 lbs.

Total uniform load to beam = 2,337 lbs/ft.

Total concentrated load to beam = 2,200 lbs.

Moment at mid-span (simple span):

Uniform load $M = wL^2/8 = 2,337 \text{ lbs/ft.} \times (13.33')^2/8$
 $= 51,907 \text{ ft.-lbs.}$

Concentrated load $M = PL/4 = 2,200 \text{ lbs.} \times 13.33'/4$
 $= 7,332 \text{ ft.-lbs.}$

Total moment = 59,239 ft.-lbs.

"S" required = $12 M/f = 12(59,239)/18,000$

= 39.49 in.³ (ok)

$$\ll 89.4 \text{ in.}^3 \text{ (S furnished)(ok)}$$

Contractors will generally use material in his yard for steel beams. He also considers deflection because if he furnishes a beam with too much deflection he will be giving concrete away.

Check Deflection

$$\text{Simple beam concentrated load: } \Delta = 4ML^2/48EI$$

$$\text{Simple beam uniform load: } \Delta = 5wL^4/384EI = 5ML^2/48EI$$

$$\Delta = \frac{[4(7.33 \text{ K-ft.})(13.33' \times 12)^2 + 5(51.91 \text{ K-ft.})(13.33 \times 12)^2]}{48(29 \times 10^3 \text{ ksi})(804 \text{ in.}^4)}$$

$$\Delta = 0.0066 \text{ ft.} = \frac{1}{16}$$

Deflection is negligible. If more than 1/4", adjust falsework at quarter points.

Check Bracing (Ref. AISC, Eight Edition, pg. 2-51)

$$\text{Max. stress in beam: } f = M/S = 59.2 \text{ K-ft.}(12)/89.4 \text{ in.}^3$$

$$f = 7.95 \text{ ksi}$$

Using actual stress, compute required bracing length:

$$L = \frac{12 \times 10^3}{f \bullet 12d/A_f}$$

$$L = \frac{12,000}{7.95 \text{ ksi} \bullet 12(18")/415 \text{ in.}^2} = 29.0 \text{ ft.}$$

Therefore, no bracing required except at end reaction.

Check Piling

Check piling in the second bay of the center span. Use reaction (simple beam) from 7 beams supported by 8 piling.

$$\text{Load: Dead load} + 20 \text{ lbs/ft.}^2 \text{ uniform live load} \\ = 2,112 \text{ lbs/ft.} + (20 \text{ lbs/ft.} \times 7.42') = 2,260 \text{ lbs/ft.}$$

$$\underline{2,260 \text{ lbs/ft.}} \bullet 13.33' \bullet \underline{7 \text{ beams}} = 26.4^{\text{K}}$$

1,000 lbs/K	8 piling		
Add 75 lbs/lin. ft.:	$0.075 \cdot 13.33$	=	1^K
Add finisher over pile:			2.2^K
Add 12" x 12" cap:	$\frac{45.92 \text{ lbs/ft.} \cdot 6.4'}{1,000}$	=	0.3^K
	Total	=	$29.9^K = 15.0 \text{ tons}$

This should be a maximum load. Plans show to drive to 13 tons. Piling are driven using the ENR formula which usually has an adequate factor of safety. Since the load computed for a maximum condition and no distribution is considered, the load is probably okay. Since we (in design) have no control over the type of pile used, it would be better to limit the load to about 12 tons. One advantage to using timber piling is that if they can drive it without splitting it, it will probably support the load. Load should not go over 15 ton unless contractor can certify the material used.

Check Lateral Load

Design for a minimum lateral load of 2% of dead load or 100 lbs/lin. ft. KDOT recommends a minimum of 2 x 6 bracing.

$$100 \text{ lbs/lin. ft.} \cdot 16' \text{ span} = 1.6 \text{ K/bent}$$

$$2\% \text{ Dead Load} = \text{Concrete} + \text{formwork}$$

$$= (\text{load/ft.}^2 \cdot \text{width} \cdot \text{span}) \cdot 0.02$$

$$= \frac{2.11 \text{ K/ft.} \cdot 44.5' \cdot 16 \text{ ft.}}{7.42 \text{ ft.}} = 202.5 \times 0.02$$

$$= 4.05 \text{ K/bent}$$

The 7-pile bents are in the abutment berm and are not critical. The bracing for the 8-pile bents are probably critical for L/d.

$$L/d = \frac{44.5' / 7 \text{ spaces} \cdot 12"/\text{ft.}}{1.5"} = 50.86$$

$$\begin{aligned} \text{Allowable stress} &= \frac{0.30 E}{(1/d)^2} \quad (\text{see Section 5.4.1.4}) \\ &= \frac{0.3 (1,500,000)}{(50.86)^2} = 174 \text{ psi} \end{aligned}$$

Assume two braces per cross-section, therefore actual stress equals:

$$P/A = \frac{4.05 \text{ K} (1000)}{2(1.5 \times 5.5)} = 245.4 \text{ psi} > 174 \text{ psi}$$

Say okay since we are ignoring the lateral resistance of the piling. If this was a bent constructed on a pad, would recommend using “3 x” bracing to reduce L/d ratio and thus increase the allowable stresses.

Allowable lateral load on a 20d spike is approximately 176 lbs. (ACI-SP4, Table 4-8, for douglas fir or southern pine). There should be a minimum of 4 spikes per pile, times eight piling equals 5.6 Kips, which should be sufficient to resist the lateral force provided all material is sound.

5.10 Structure Erection Calculations and Considerations

KDOT's direction on required stability calculations required of Contractors for the new Special Provision for Steel Erection.

The National Steel Bridge Alliance document S10.1 states in Section 6.3 Erection Stability on page 7 that included in erection stability is the requirement that once the “pick and place” phase of erection is complete so that...

“a sufficient number of adjacent girders are erected with diaphragms and/or crossframes connected to provide the necessary lateral stability and the structure is self supporting.”

The commentary for Section 6.3 states that:

“Removal of falsework, temporary bracing or holding cranes shall be in accordance with stability calculation provided in the erection procedure.”

This document is to clarify what may be included in “stability calculations.” It is not KDOT's intent to provide an exhaustive nor even a complete list of what should be considered “stability calculations.”

Experienced practicing Engineers should have a grasp of the principles involved in stability. Some factors affecting the overall stability or the partially constructed bridge elements include, but are not limited to:

- “Self Weight of the partially constructed bridge elements and their respective centers of gravity.
- “Any existing bearing supports or members, including falsework, that are considered to help support the partially constructed bridge elements. Care should be taken as to the actual supporting conditions at the instant the partially constructed bridge elements are considered “self-supporting.”
- “Care should be taken in considering the unbraced length of the partially constructed bridge elements. The number and location of diaphragms and cross bracing with consideration for the number of bolts that are fully tightened plays a big role in this unbraced length calculation.
- “List all possible external loads that may reasonably be applied to the partially constructed bridge elements. One of the common external loads to be considered will be wind. If the partially constructed bridge elements will remain in this temporary state for more than 24 hours, there may be a need to have an extensive list of possible external loading conditions, especially if the safety of the traveling public is involved.

- “If the permanent bearing devices do not provide adequate support in all directions to stabilize the applied loads to the partially constructed bridge elements, list all additional supports, their locations, and their intended resistance clearly on the erection plans. Note: friction is not considered a positive connection and should be discounted when considering stability.

For calculations to support the above stated stability conditions, the Engineer may need to review the following design guides and specifications. This is not considered an exhaustive list.

“AASHTO LRFD Bridge Construction Specifications, Section 11.

“AASHTO LRFD Bridge Design Specifications, Section 6.

“AASHTO/NSBA Collaboration Document S10.1, Steel Bridge Erection Guide Specification.